

STRONG

**Service Manual
(SRT4355)**

Contents

- 1. Technical specifications**
- 2. Block Diagram**
- 3. Circuit Drawing**
- 4. List of Error codes**
- 5 Trouble Shooting**
 - 3.1 Trouble shooting**
 - 3.2 Check point about badness STB**
- 6. Materials list**
 - 6.1 Main PCB materials list**
 - 6.2 Front PCB materials list**
- 7. Software download instructions(OTA and PC download)**
 - 7.1 Program Download**
 - 7.2 System Upgrade**
- 8. Specification of required cables for software download**
- 9. Data Sheet**



1. Technical specifications

1.1. Conditional Access Interface

PCMCIA	2. Slot(type I or type II) DVB Common Interface Standard (Viaccess, Nagra Vision, Conax, Cryptoworks, Irdeto, ASTON)
--------	--

1.2. Tuner & Channel

<Digital Part>

Input Connector	F-type, IEC169-24, Female
Frequency Range	950MHz to 2150MHz
Input Impedance	75ohm unbalanced
Signal Level	-25 to -65dBm
IF Bandwidth	55MHz
LNB Power	Vertical: +13V Horizontal: +18V Current: Max, 400mA
Polarization	13V/18V or Skew Control
22kHz Tone	Frequency: 22±4kHz Amplitude: 0.6±0.2V
DiSEqC control	Version (1.0 & 1.2) Compatible
Demodulation	QPSK
Input Symbol Rate	2-45 Ms/s
FEC Decoder	Convolution Code Rate 1/2, 2/3, 3/4, 5/6, and 7/8 With Constraint Length K=7

1.3. System & Memory

Main Processor	L64108(LSI-LOGIC)
Flash Memort	1Mbyte
Program Dram	2Mbyte
EEPROM	8kbyte
Channel Memory (Total : 3500)	Digital Channel: 3000 Analog Channel: 500
Multi-Satellite	UP to 64
Multi-Language Menu	English/Spanish/French/Italian/German/Portuguese
Front	7 keys, 4-digit 7-segment display
Remote Controller	30-31 keys, IR Remote Control



1.4. MPEG Transport Stream & A/V Decoding

<Digital Part>

Transport Stream	MPEG-2 ISO/IEC 13818 Transport Stream Specification
Profile Level	MPEG-2 MP@ML
Input Rate	Max. 40Mbit/s
Aspect Ratio	4:3, 16:9
Frame Rate	25Hz for PAL, 30Hz for NTSC
Video Resolution	720x576(PAL),720x480(NTSC)
Teletext	Through VBI
Audio Decoding	MPEG/MusiCam Layer I & II
Audio Mode	Single channel/Dual channel joint stereo/Stereo
Frequency Response	20~20kHz, <+/- 2dB 60Hz~18kHz <+/- 0.5dB
Sampling Rate	32, 44.1, 48kHz

1.5. A/V & Date In/Out

TV Scart Output	RGB, CVBS, L, R Output with Volume control
VCR Scart In/Out	CVBS, L, R In CVBS, L, R Out
RCA Output	CVBS, L, R Output(Yellow, White, Red Hack) with Volume Control
0V/12V Output	RCA Jack Output(Black Jack), Max. 150mA
Data Interface	RS-232, Bit Rate: 115200baud Connector: 9-pin D-sub type

1.6. RF-Modulator

RF-Connector	75w IEC169-2, Male/Female
Frequency	470MHz to 860MHz
Output Channel	CH 21-69 for the Demodulator
TV Standard	PAL B/G/I/D/K Selectable by Menu Setting
Audio Output	Mono with Volume Control
Preset Channel	CH 40 (or TBD). Soft ware changeable by Menu screen



1.7. Power Supply

Input Voltage	AC90 to 260V, 50Hz/60Hz
Type	PWM Regulator
Power Consumption	Max. 40W(without Positioner)
Stand-by Power	<= 10W
Protection	Separate Internal Fuse The input shall have the lightning protection

1.8. Physical Specification

Size (WxHxD)	280x55x235mm Excluding the foot. Foot height is 10mm.
Weight	2.0Kg

1.9. Environmental Condition

Operating Temperature	0~40C
Storage Temperature	-10C~+50C
Operating Humidity Range	10~85% RH, Non-condensing
Storage Humidity Range	5~90% RH, Non-condensing



2. Block Diagram

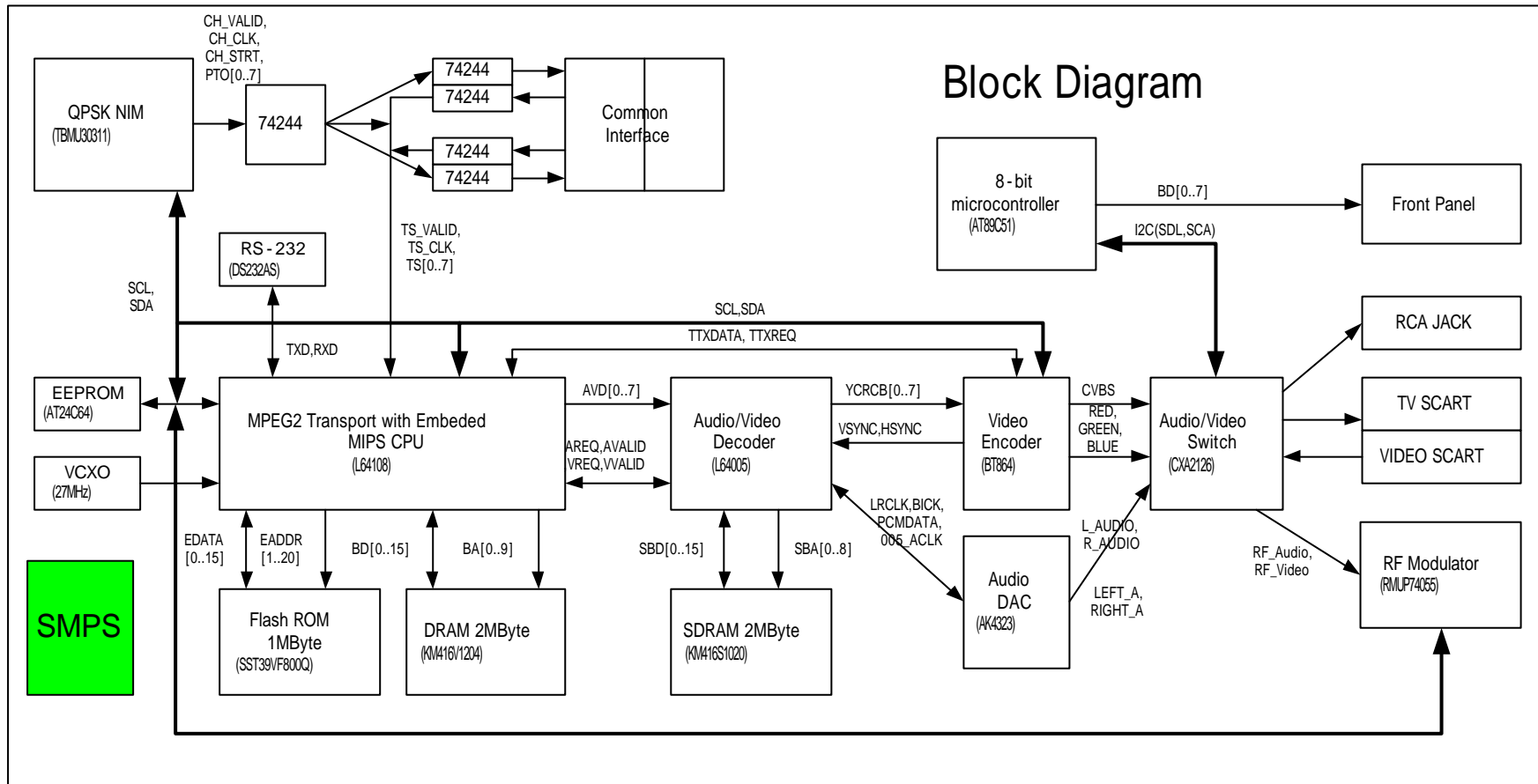

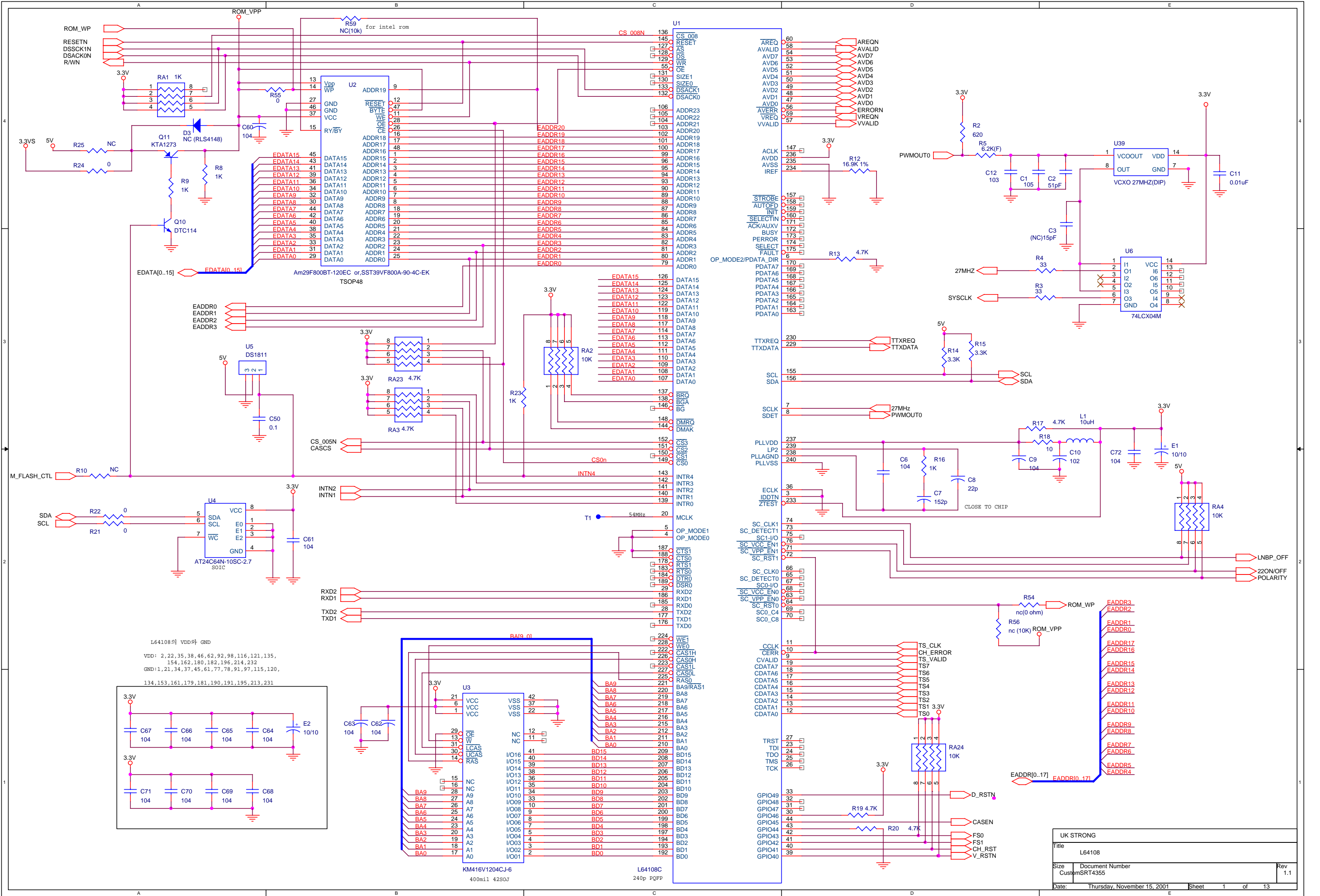

L64108의 VDD와 GND
 VDD: 2, 22, 35, 38, 46, 62, 92, 98, 116, 121, 135, 154, 162, 180, 182, 196, 214, 232
 GND: 1, 21, 34, 37, 45, 61, 77, 78, 91, 97, 115, 120, 134, 153, 161, 179, 181, 190, 191, 195, 213, 231

UK STRONG		
Title	L64108	
Size	Document Number	Rev
Custom	SRT4355	1.1
Date:	Thursday, November 15, 2001	Sheet 1 of 13

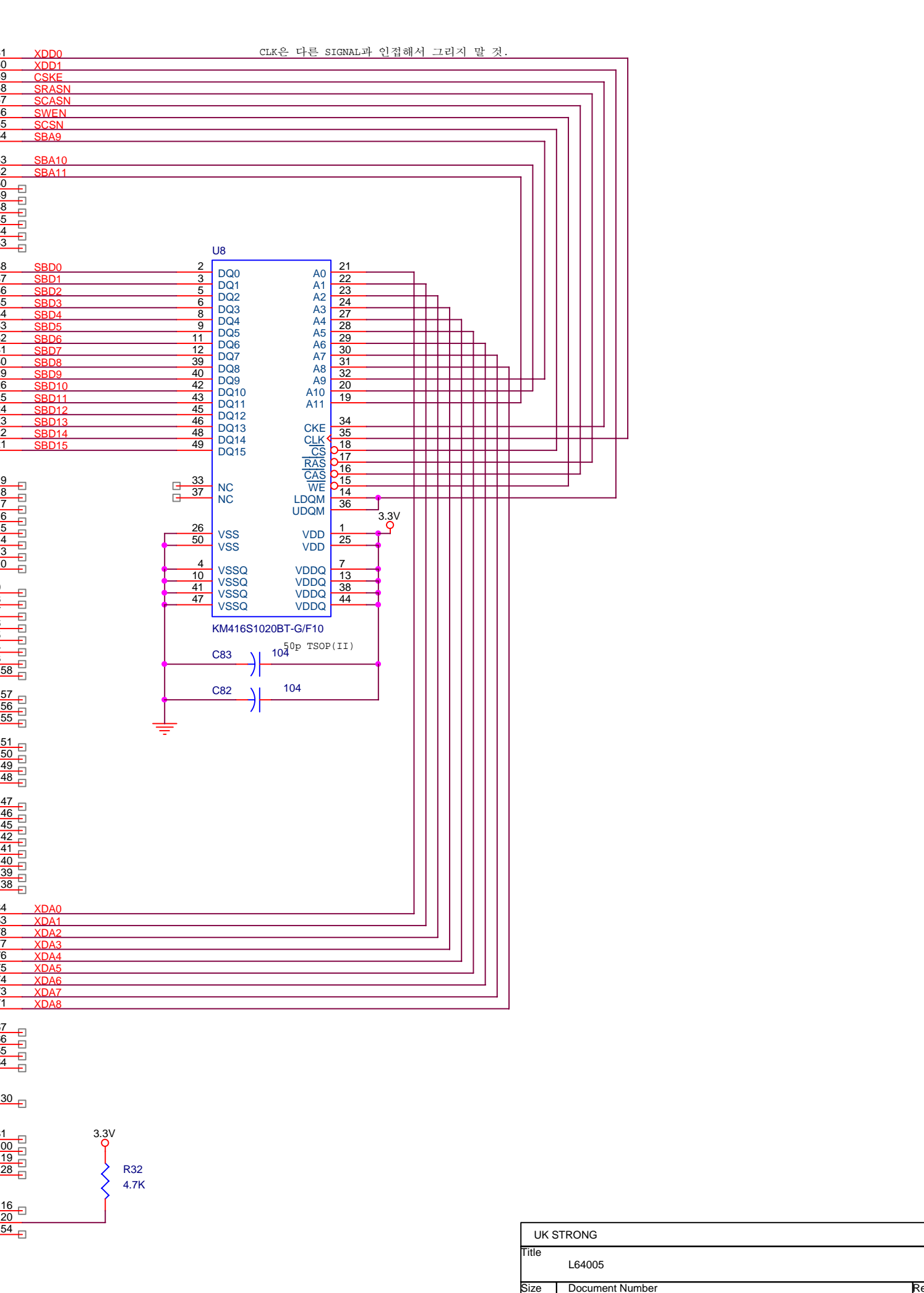
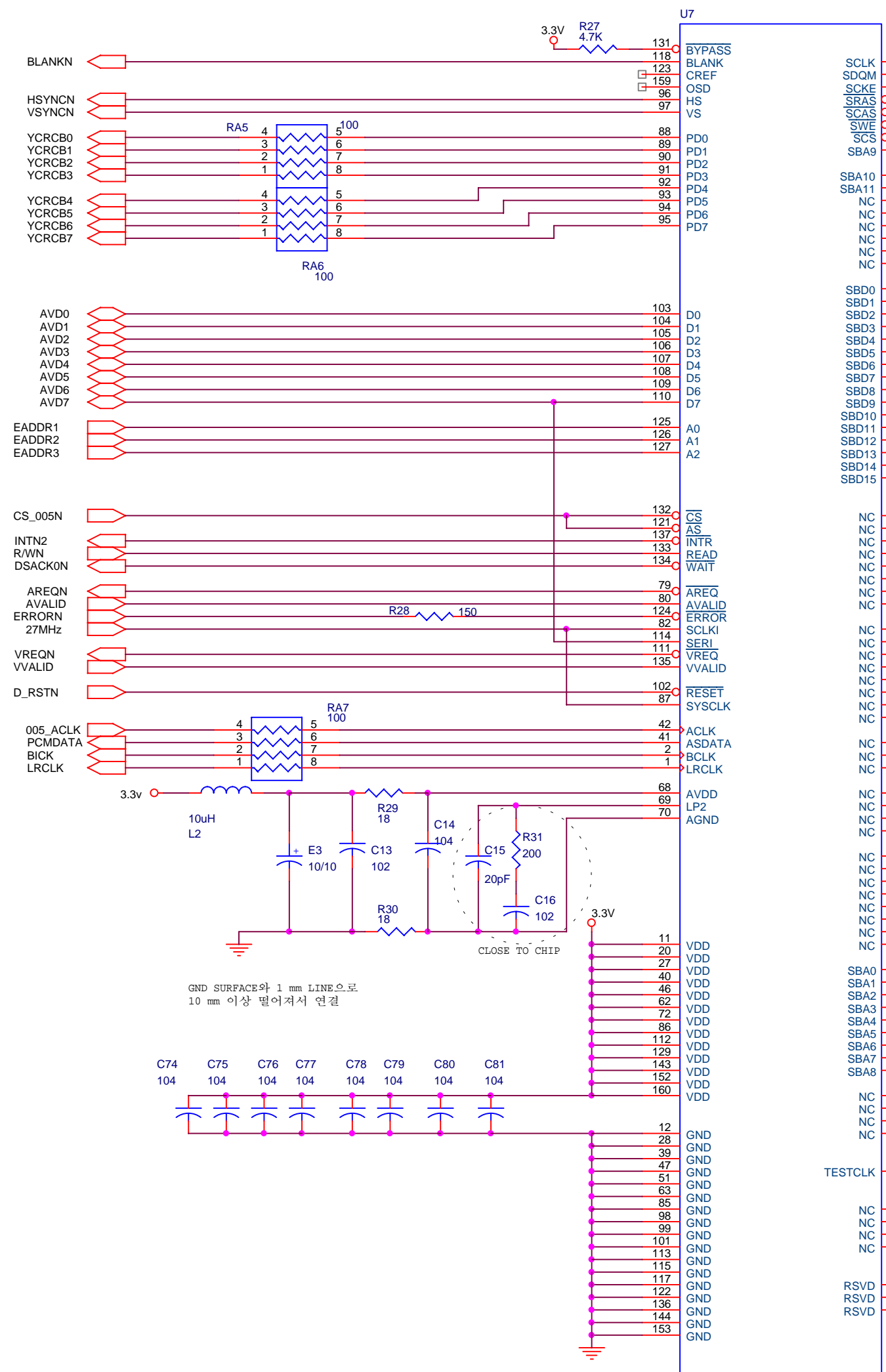

CLK은 다른 SIGNAL과 인접해서 그리지 말 것.

GND SURFACE와 1 mm LINE으로
10 mm 이상 떨어져서 연결

CLOSE TO CHIP

UK STRONG		
Title L64005		
Size	Document Number	Rev
Custom	SR T4355	1.1
Date:	Thursday, November 15, 2001	Sheet 1 of 13

L64005 160p PQFP

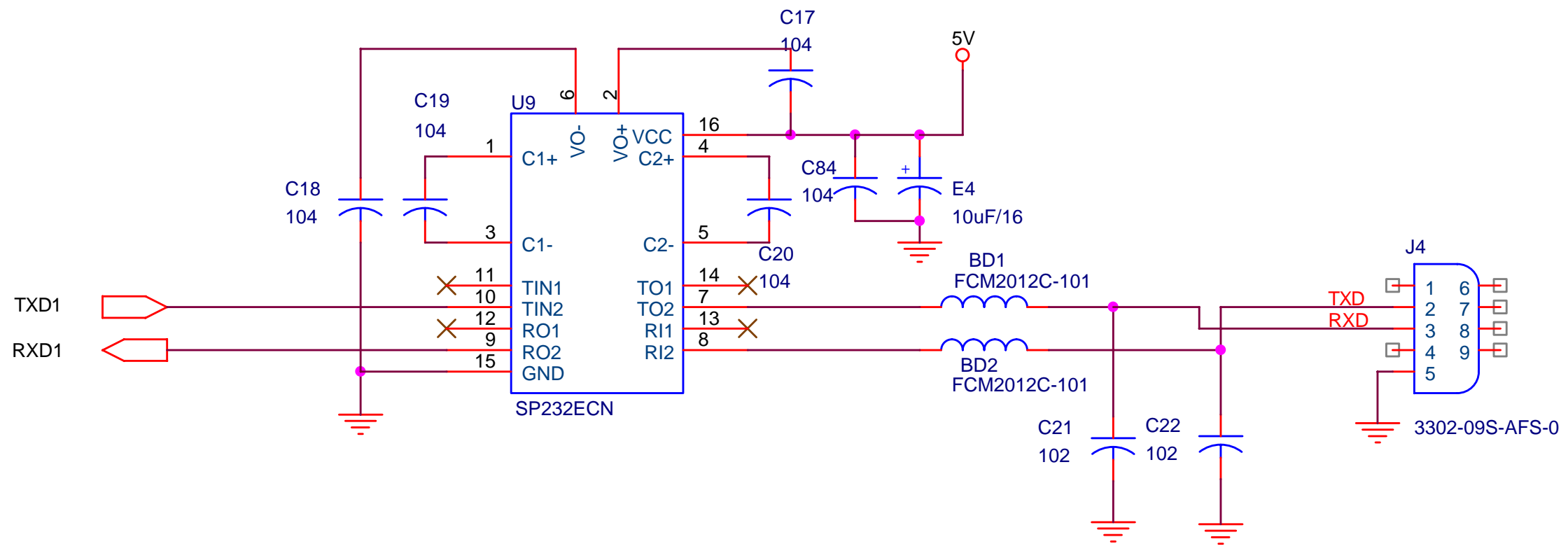

UK STRONG		
Title RS232C		
Size A	Document Number SRT4355	Rev 1.1
Date:	Thursday, November 15, 2001	Sheet 1 of 13

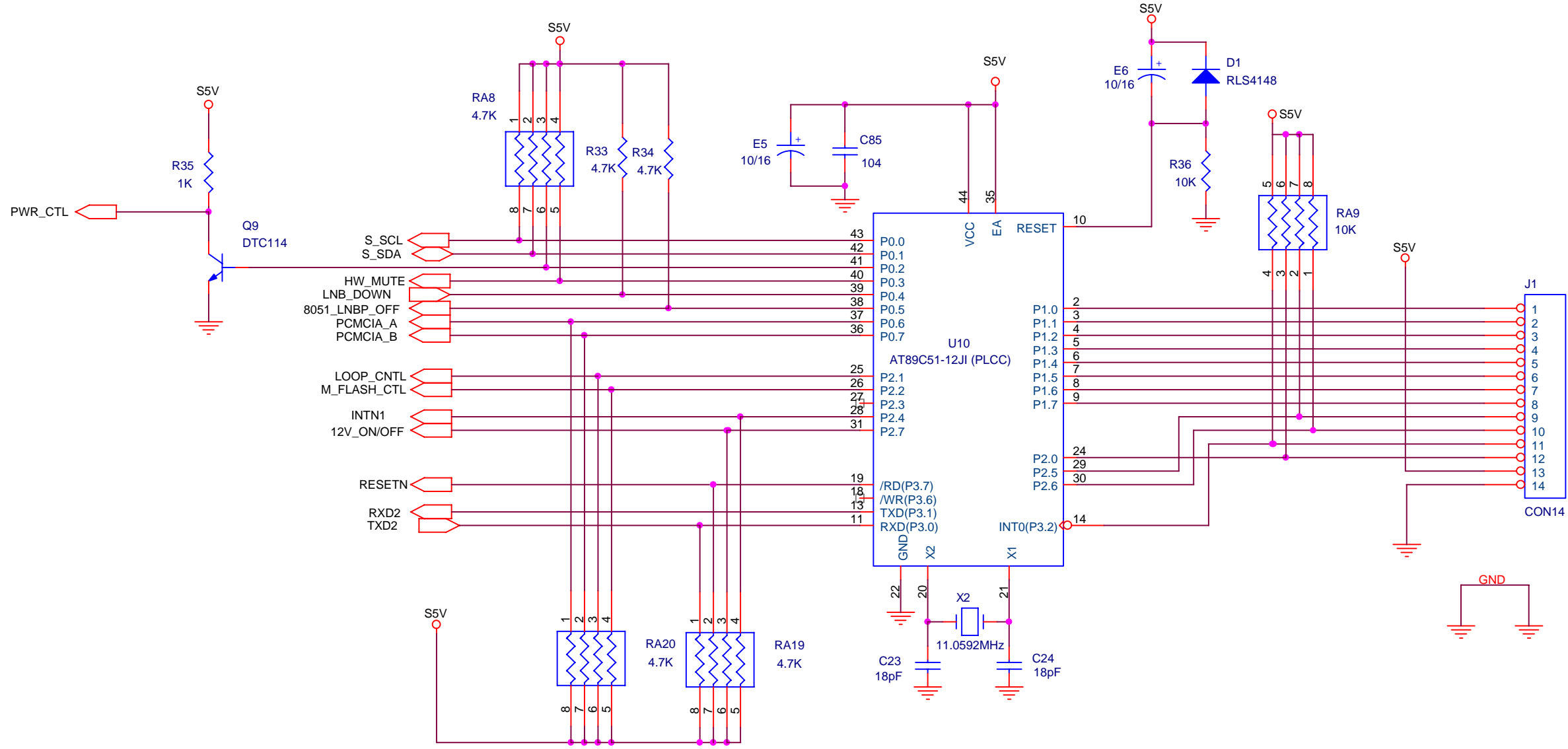

UK STRONG		
Title MICOM		
Size B	Document Number SRT4355	Rev 1.1
Date:	Thursday, November 15, 2001	Sheet 1 of 13

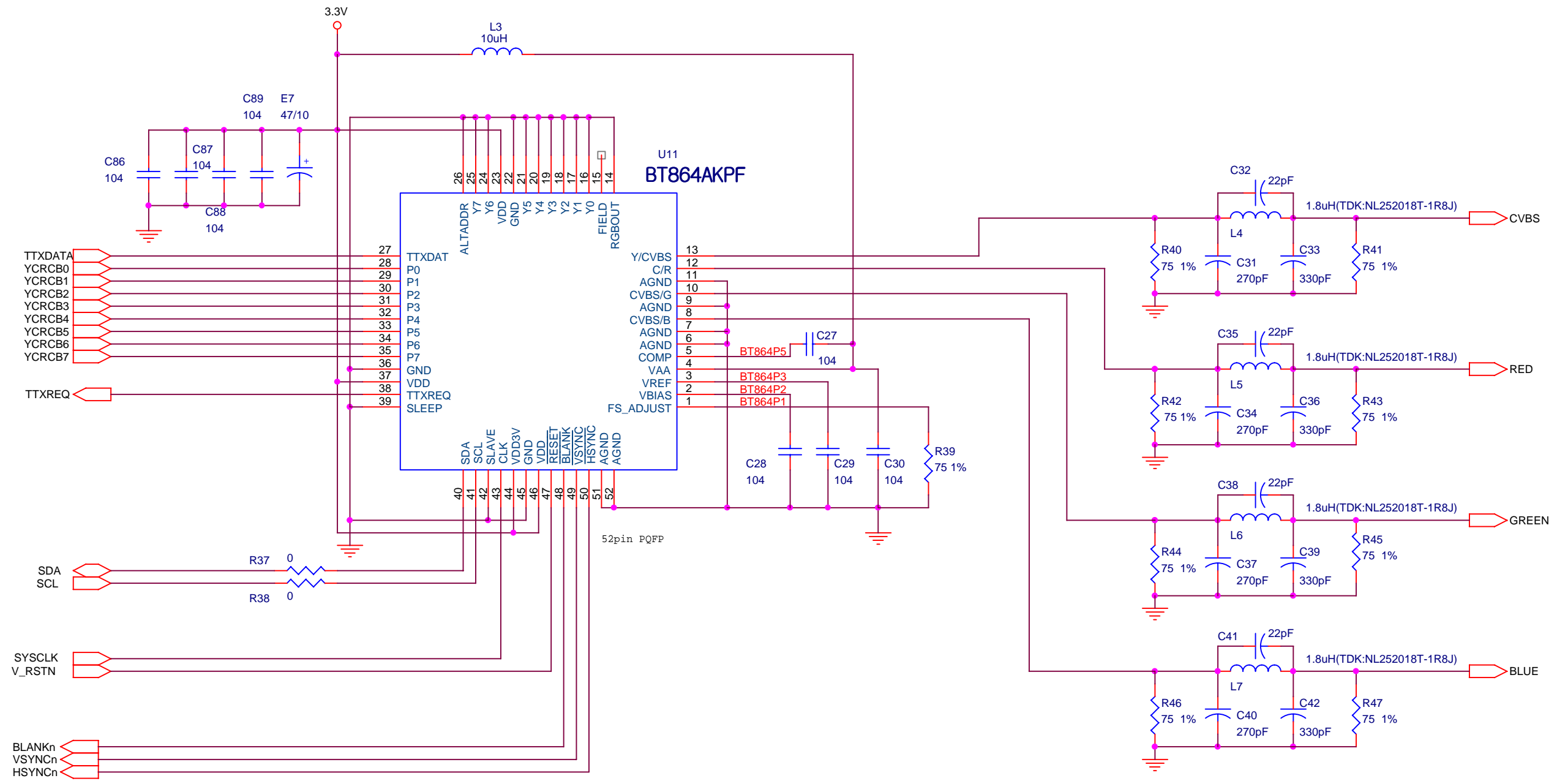

UK STRONG		
Title VIDEO ENCODER		
Size B	Document Number SRT4355	Rev 1.1
Date: Thursday, November 15, 2001	Sheet 1	of 13

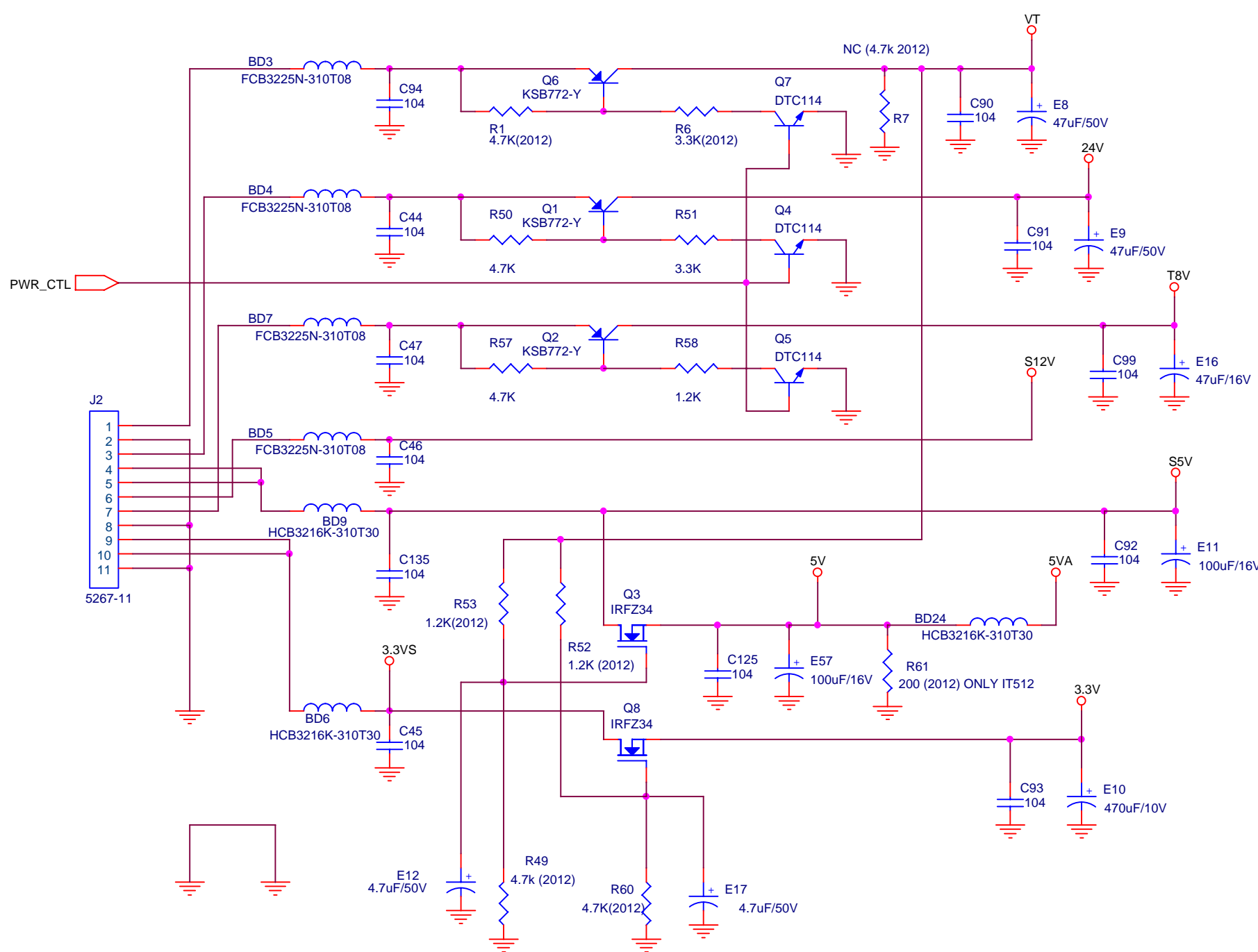

UK STRONG		
Title POWER		
Size B	Document Number SRT4355	Rev 1.1
Date:	Thursday, November 15, 2001	Sheet 1 of 13

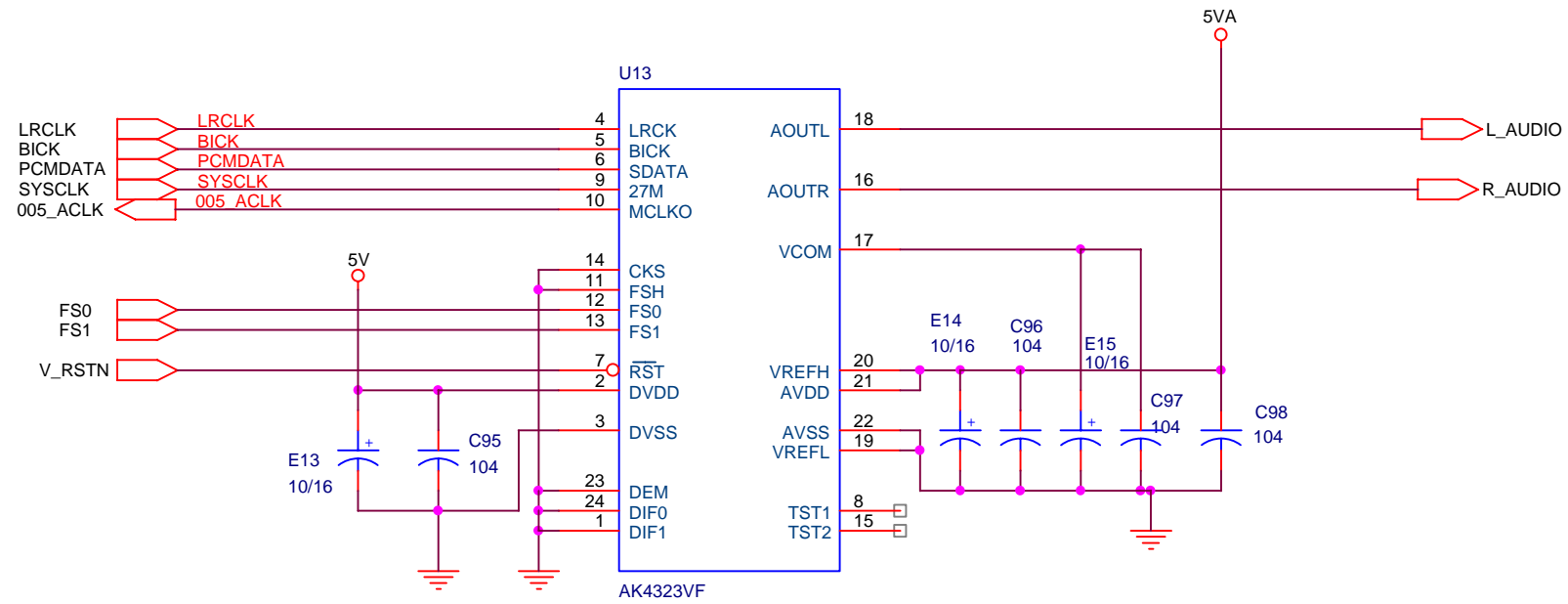

UK STRONG		
Title AUDIO DAC		
Size B	Document Number SRT4355	Rev 1.1
Date:	Thursday, November 15, 2001	Sheet 1 of 13

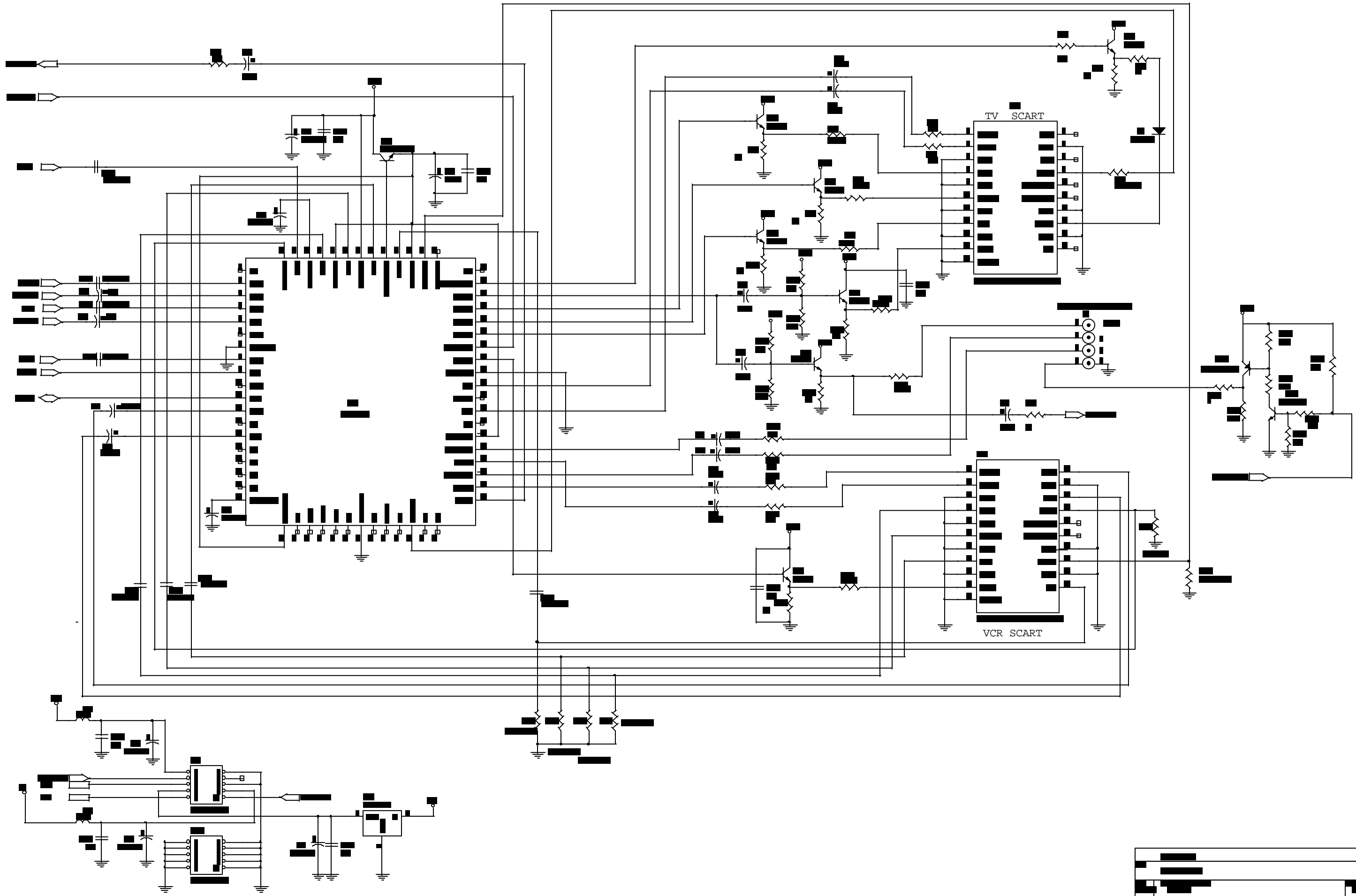

TV SCART

VCR SCART

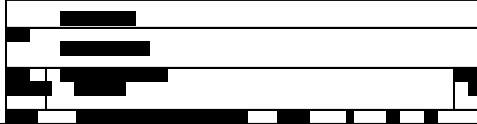

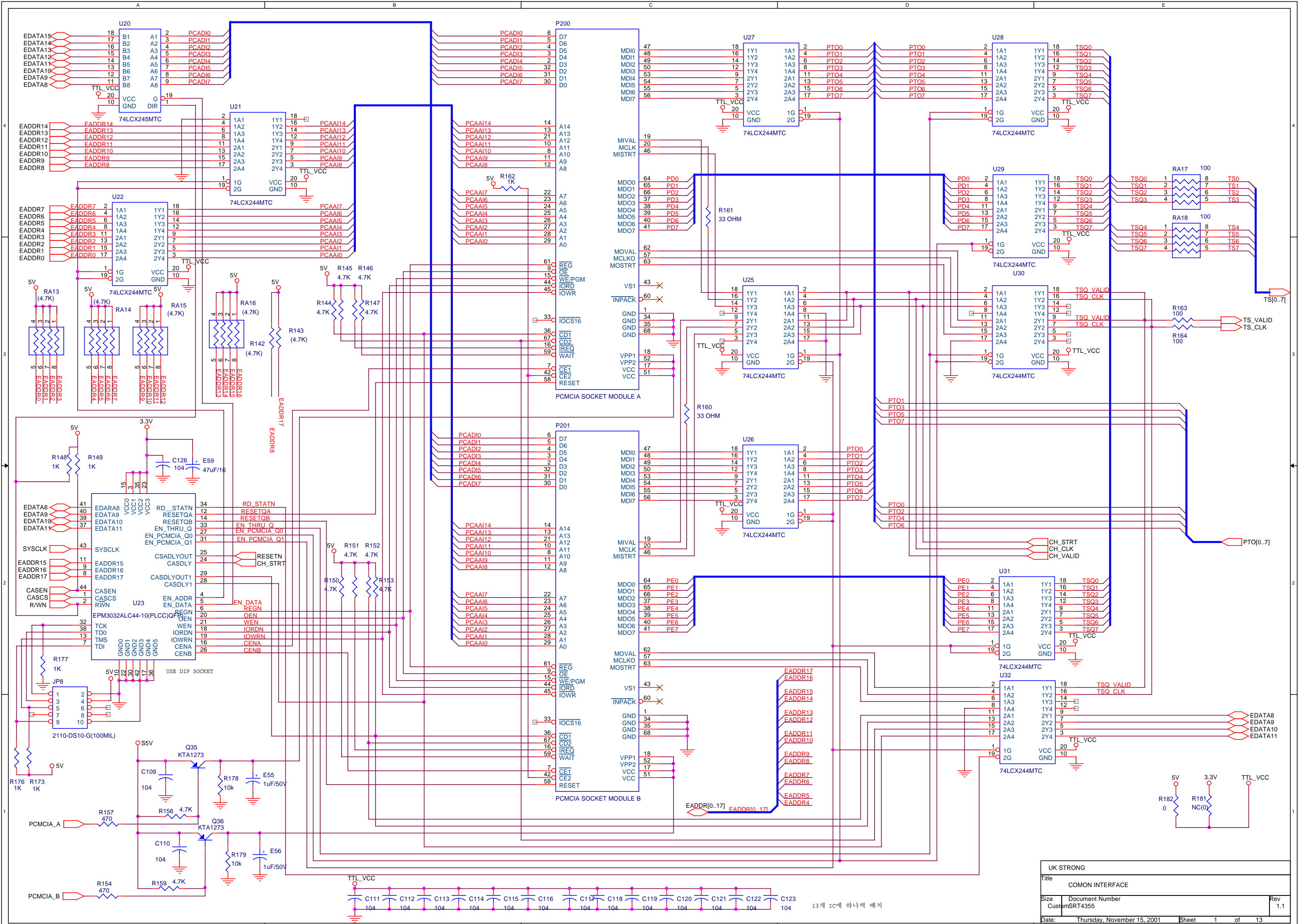

13개 Ic에 하나씩 배치

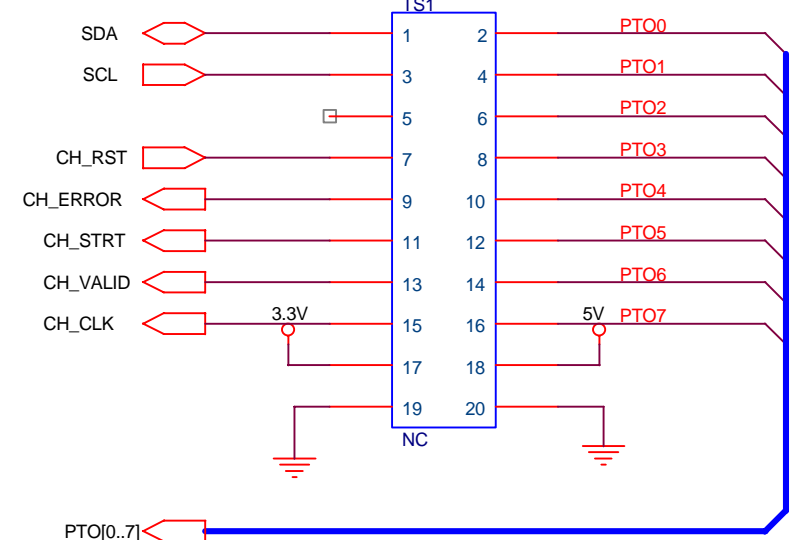
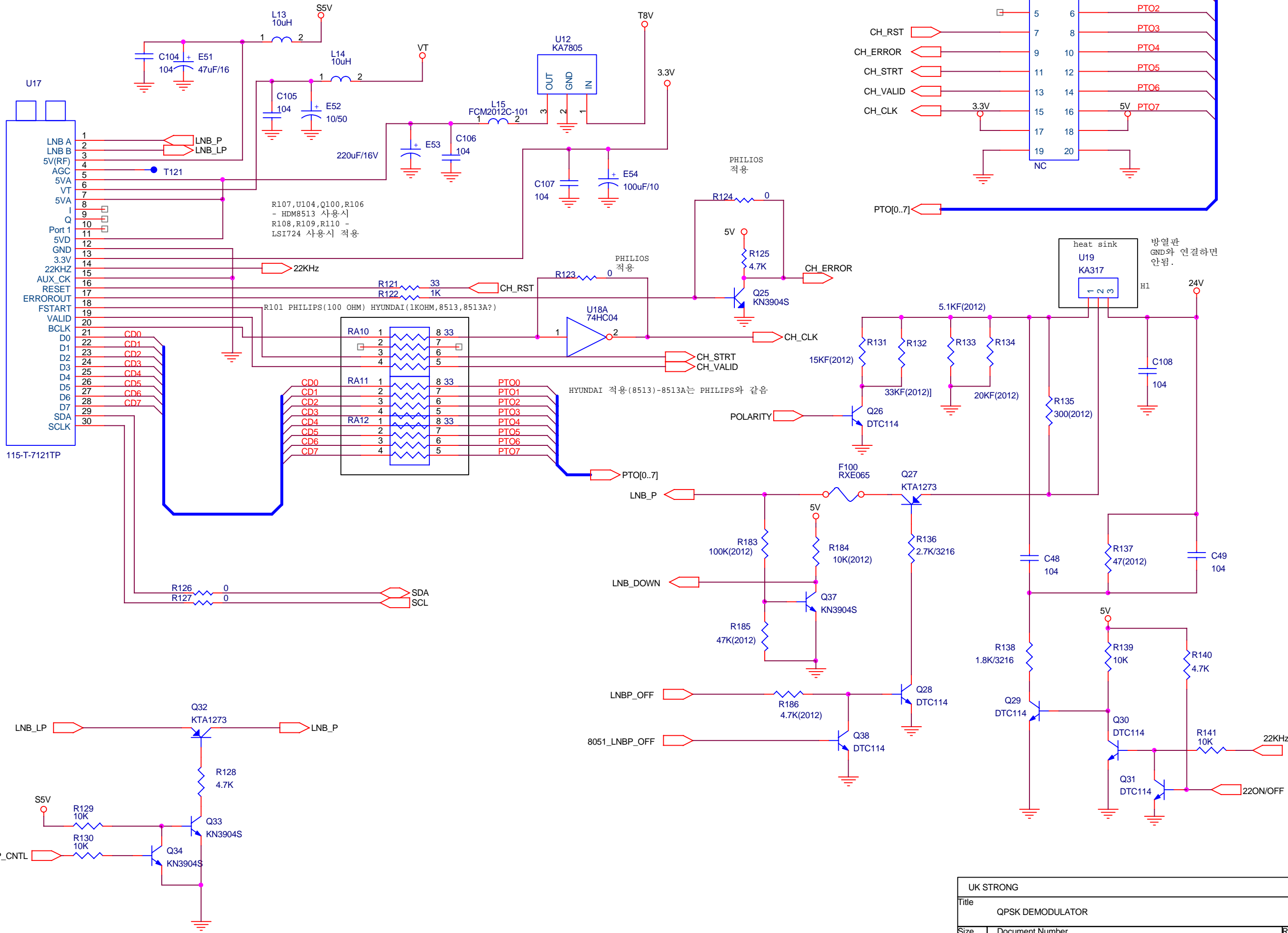

heat sink
U19
KA317

방열판
GND와 연결하면
안됨.

UK STRONG		
Title QPSK DEMODULATOR		
Size CustomSRT4355	Document Number	Rev 1.1
Date: Thursday, November 15, 2001	Sheet 1	of 13

A

B

C

D

E

4

4

3

3

2

2

1

1

A

B

C

D

E

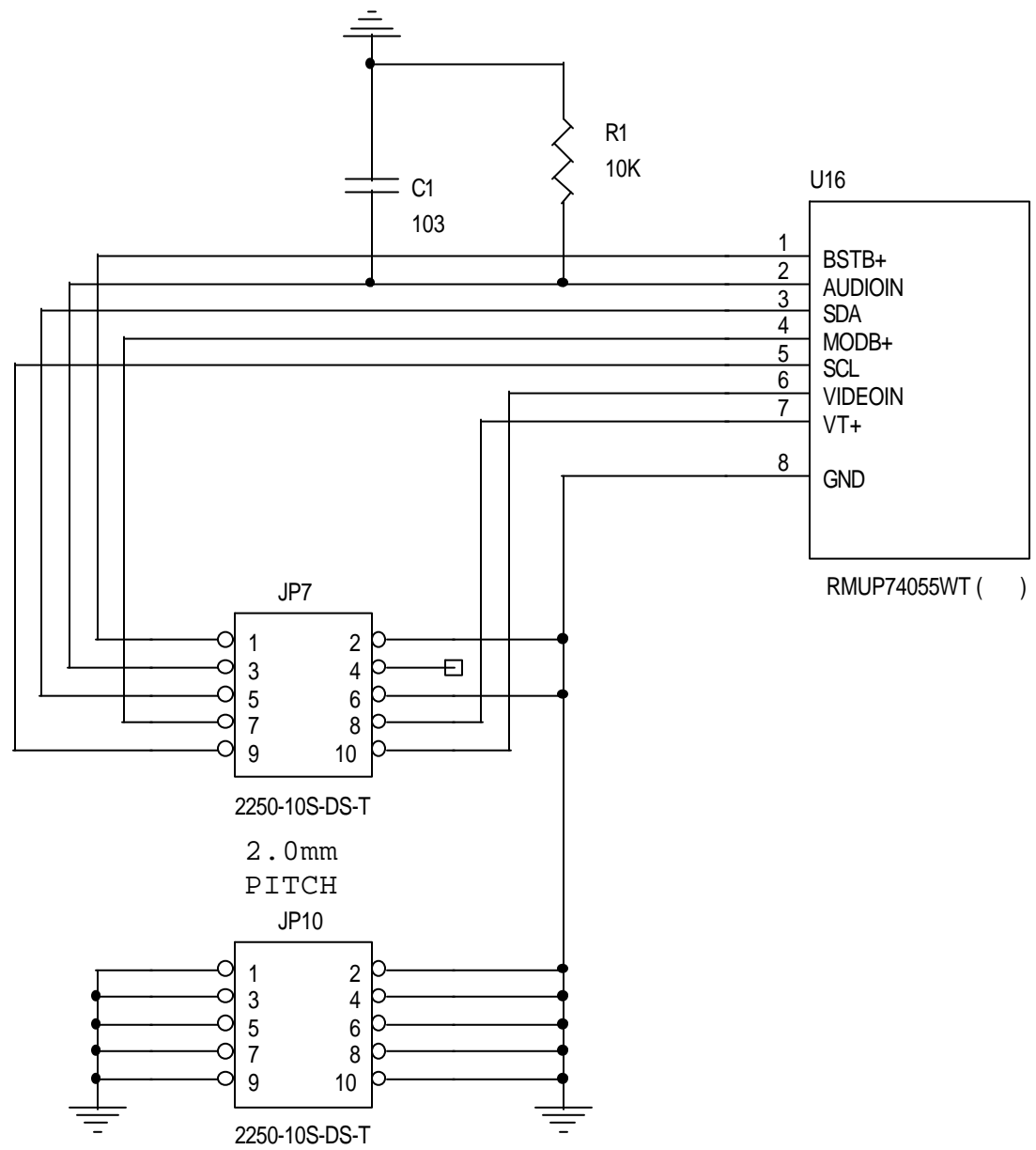

Title		
RF MODULATOR SUB PCB		
Size	Document Number	Rev
A		1.1
Date:	Tuesday, November 20, 2001	Sheet 11 of 11

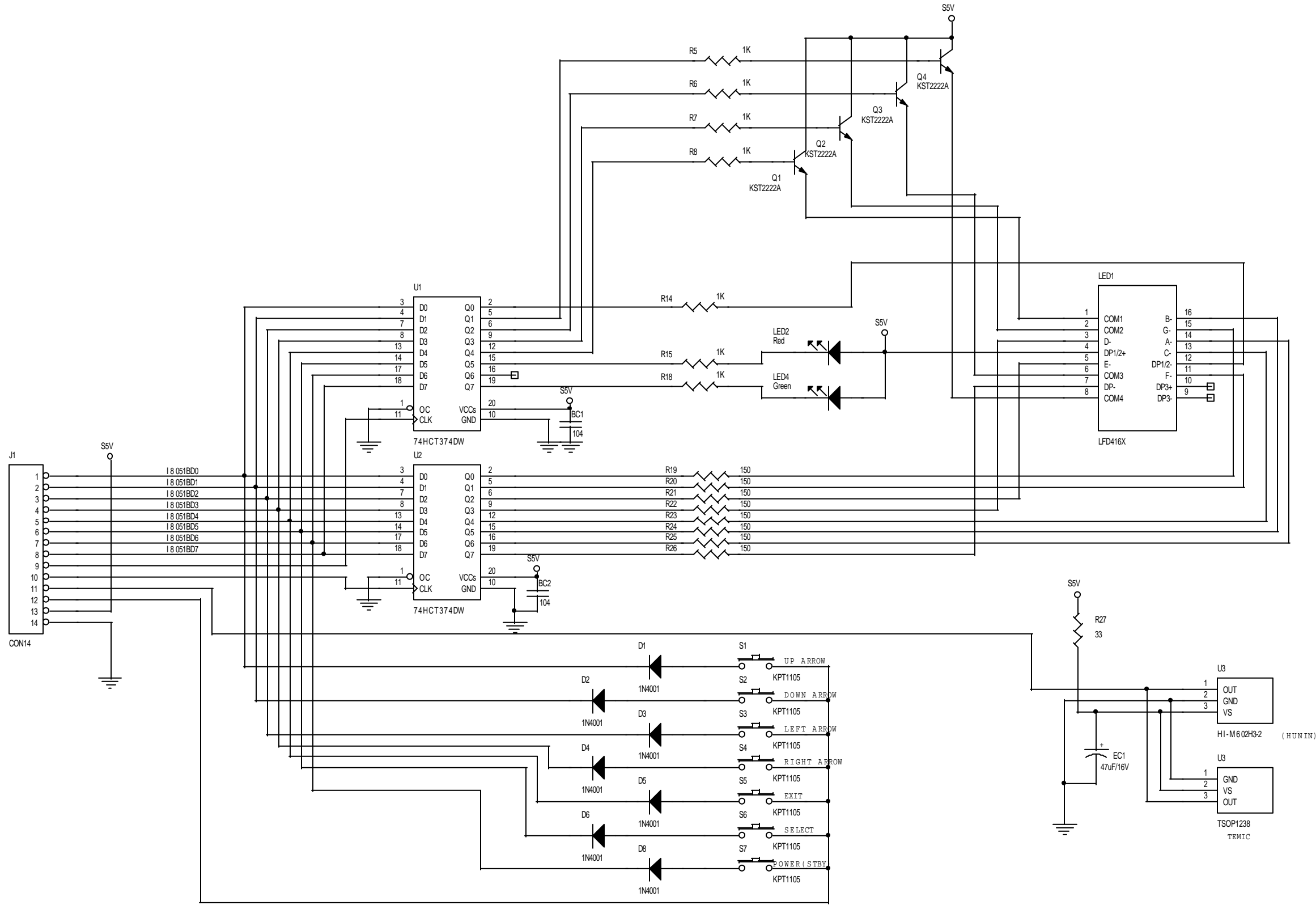

UK STRONG		
Title FRONT CIRCUIT		
Size B	Document Number	Rev 1.1
Date: Friday, July 27, 2001	Sheet 1	of 1



4. List of Error codes

E001: Tuner Error.

E002: EEPROM Error.

E003: RF Error.

E004: BT864 Error.

E005: L64005 Error.

E006: DRAM Error.

E007: STV0056 Error.

E008: ATuner Error.

5. Trouble Shooting

There may be various reasons for the abnormal operation of the receiver. Check the receiver according to the procedures shown below.

If the receiver does not work properly after checking it, please contact the dealer. Don't open the receiver cover. It may cause a dangerous situation.

5.1. trouble shooting

Symptom	Cause	Remedy
The display on front Panel does not light up.	The power cord is Not plugged in	Check that the power cord Is plugged in to the wall outlet.
No picture or sound.	Wrong connection of The Audio/Video output Of the receiver to TV. Audio muting. TV power off.	Connect the Audio/Video Output of the receiver to TV correctly Press the MUTE button. Turn TV on.
No picture.	The receiver can't Receive the signal. Incorrect values of some Tuner parameters. Wrong direction of the dish	Check the antenna cable, Replace the cable, or connect The cable to the receiver tightly. Set the values of tuner Parameters correctly in System set-up menu. Check the signal strength With a spectrum analyzer and Adjust your dish correctly.

The remote controller Does not working.	The batteries of the Remote controller are Not inserted or Exhausted.	Check whether the batteries Are inserted correctly in your Remote controller. Check the batteries, and if Exhausted, replace the Batteries of the remote Controller.
---	---	--

5.2. Check point about badness STB

5.2.1. When nothing appears on TV screen(front panel display "0000")

(1) Check the SMPS' s voltage

- Power Connect(J2) -> pin4, pin5 : 4.75~5.25V
- Power Connect(J2) -> pin6 : 10.2~12.6V
- Power Connect(J2) -> pin3 : 21V~24V
- Power Connect(J2) -> pin1 : 27V ~ 33V
- Power Connect(J2) -> pin7 : 7.5~8.5V
- Power Connect(J2) -> pin9, pin10 : 3.2~3.5V

Action) : If voltage is not normalcy, it change, and measure again SMPS first. Still, SMPS is normalcy if voltage is low. There are possibility that is badness with parts that use the voltage in Main Board.

(2) Confirm by Oscilloscope whether 27 MHz break out in R10 and R11.

Action) : if 27Mhz do not break out, X1(27Mhz CRYSTAL), or U6(74LCX04) change .

(3) ROM Read cycle(Pulse) should be happened continuously through Oscilloscope at Power off/on in pin 26 of U2(39vf800A Flash ROM).

(If U2's pin 26 is 3.3V by Voltage Meter, it is normalcy)

Action) : if U2-pin26 is measured (0V ~ 2V) by Voltage Meter, U2(39VF800A FLASH ROM) change, still, change U1(L64108 CPU) if do not act.

(4) Flash-Rom of Start Control Signal uses reset, chip-Select

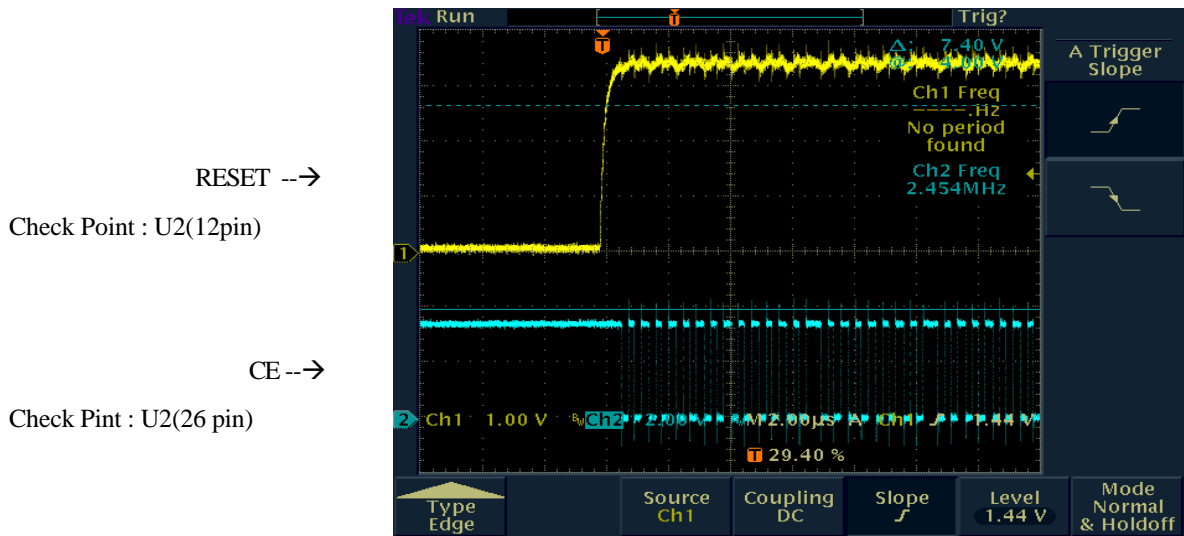

Action) : If the flash-Rom(U2) not operation. , must be Checking chip-select pin from L64108. Replacement of part is required. Because Reset and Chip-Select signal is not Booting.
Also , Checking soldering or Chip is consider flash-rom and CPU
Where are replace of component Part, and Check the insertion of part

(5) Confirm that Message is displayed when interlink STB and PC by RS232 CABLE and did Power off/on

Execute Hyper terminal in PC and do together Setup with next time

Baud Rate: 115,200bps.

Data bit:8 bit

Parity bit :none

Stop bit :1

Control: none

1)When Message is not displayed:

1. Do AC Power put on in state that click Menu and Select key simultaneously after AC power put off, (method by boot mode Booting) Still, if any message is not displayed, it changes U2(39VF800A flash ROM)



2. if "starting boot" message is displayed, Do Download again by suitable Firmware to model.
3. Do STB Power off/on after Download is completed.
4. If screen is displayed, it does FACTORY RESET necessarily.

2) When Message is displayed:

(Message can be different according to Firmware Version)

```
Set ACLK <32000>
PHILIPS TDA8044 connected
IT520S SET-TOP BOX MONITOR v1.10 BY INTEGRA TELECOM
Nov 02 2000,23:35:35, http: www.integra.co.kr
>size of sysconfig=140
flash pattern(ffff)
flash pattern(ffff)
flash pattern(ffff)
PHILIPS TDA8044 connected
Enable AV Interrupts
launch OSD
launch OSD 3
Set ACLK <3>
launch OSD 4
launch OSD 4.5
launch OSD 5
intr EN end[D:0][AV:3c00]
RegValue23=3
AVO:OSD Initialized
AV decoder and OSD initialized
```

1. When " I2C ERROR " , " EEPROM ERROR " , " TUNER CONNECT FAIL " message happens After AC POWER OFF, measuring resistance between U1's pin 156 and GND, pin 155 and GND, if it is measured (20ohm ~ 0 ohm), L64108 (CPU) must change.
2. When "EEPROM ERROR" Message happens



U4 : EEPROM(24C64) change

3. When "Tuner connect Fail" Message happens
If POWER supplied to Tuner is normalcy, Tuner must change.
4. When " FLUSH DRAM " Message happens
U7(L64005) and U8(KM416S1020) Re-soldering do, and
change U7(L64005) if is happened again.
5. Normal Message as being displayed, change MICOM if TV screen
does not come

5.2.2. When "NO SIGNAL" message appears

(1) U19:(KA317(Regulator)) -> pin 3 : 21V~24V

U19:(KA317(Regulator)) -> pin 2 : 13V /18V

If confirm that voltage is measured and is not measured, U19 change

Action) : When U19's(KA317) input voltage is low, do you change SMPS,
do U19 Voltage Line check in SMPS if change SMPS and is
low.

(2) Measure by Voltage Meter(Oscilloscope) whether VERTICAL(13Volt) or
HORIZONTAL(18Volt), 22KHz(ON/OFF) is displayed normally measuring
voltage of F100's Lead(or Tuner LNB OUT PORT) when do SCAN
satellite in INSTALL MENU.

(LNB supply voltage check)

(3) When LNB voltage(13V/18V) is not displayed, it changes Q27(TR:kta1273) if
13V/18V is displayed measuring Q27's(TR:kta1273) Emitter monad by
Voltage Meter and measure whether 13V/18V is displayed in F100(Poly
Switch)

Action) : If mania is happened to F100 or Q27 after shift Tuner shift

(4) Voltage measurement supplied to TUNER

1. L13(Coil) : about 5V,

L14(Coil): about 28V ,

U12(Regulator)-Pin 3 : about 5V

(E54(+))Elect Cap) : 3.3V

Action) : If voltage is normalcy TUNER change .

2. U12(Regulator)-Pin3 : 3V~ 0V

Action) : If it is 100 ohm lows, doing AC POWER OFF and measure U12's(Regulator) 3Pin and resistance between GND, Tuner change

(5) Check I2C Control Signal

Action) : if Voltage is drop SCL as well as SDA. “ No Signal ” message will be Display at TV Screen. therefore each of part check have to SCL with SDA of Voltage 3.2 ~3.5V. Check the install chip-position and short of solder, cold solder, etc. Where are replace of component Part, Check the insertion of part

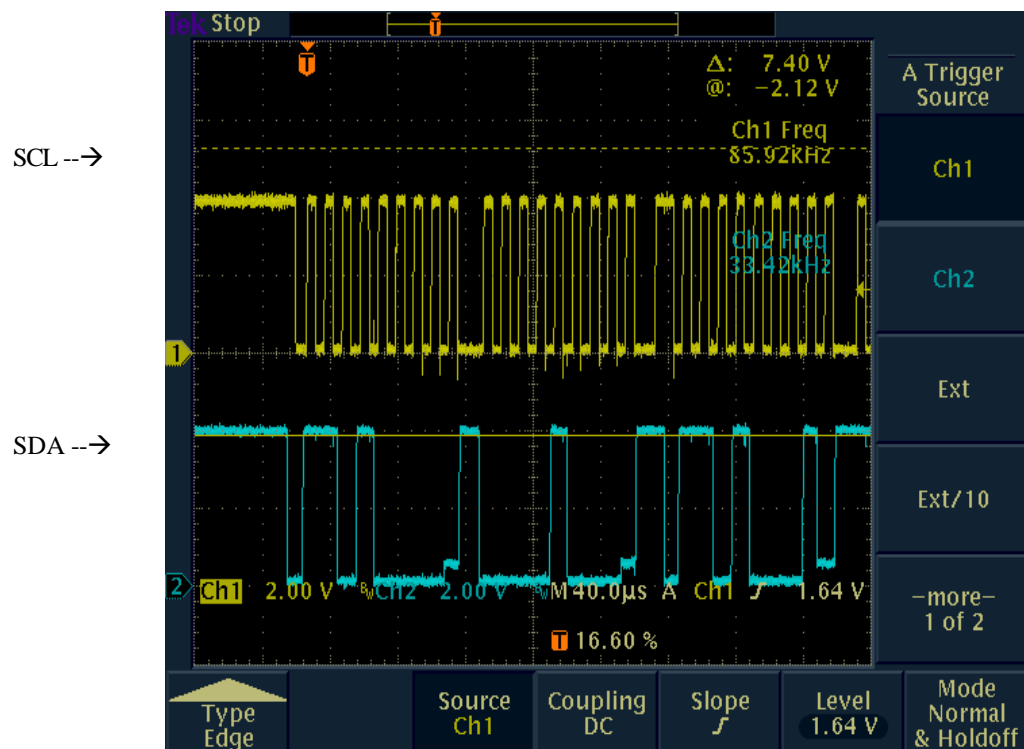

(6) Changing SMPS test

(7) Try scan again after Factory reset

Action) : Do U2(39VF800A Flash ROM) and U1(L64108 CPU) Re-solder if “Wait to Reset setting” Message comes continually when did

Factory Reset. Still, change U2(39VF800A Flash ROM) if do not become.

5.2.3. "CI CARD INITIALIZING NOW..." Message becomes Display continually on screen and when Menu transfer is slow Firmware again Download do .

5.2.4. When do not act whether FRONT 7-SEGMENT(DISPLAY) acts strangely

(6) Change FRONT PANEL

(7) Change MICOM(U10) (AT89C51)

U10 : Confirm by SCOPE whether 11.0592 MHzs break out in pin 21

(8) Confirm by SCOPE whether 11.0592 MHzs break out in U10-pin 20, 21

5.2.5. When VIDEO screen gets into Scratch occurrence

(1) If scratch is happened on Video screen and Audio noise or stop phenomenon is happened Tuner change .

(2) Audio is normalcy and if scratch is happened Video screen U7 : (L64005)

U8 : (km416S1020 sdram) change

(3) When Video Color is badness, U11 : (BT864) change.

(4) After Power ON, when that stop screen phenomenon happens U13 : (AKM4323) change

(5) Video Filter from Bt864A (Digital Video Encoder)

Action : If the Color signal is not operation. Should be Checking

43pin(SYSCLK) 27Mhz Of U11 and VCC(3.3V) if you have

checking, If No problem. Check the install chip-position and short of

solder, cold solder, etc. Where are replace of component Part, Check

the insertion of part

CVBS -->

(LOW active) RESET -->

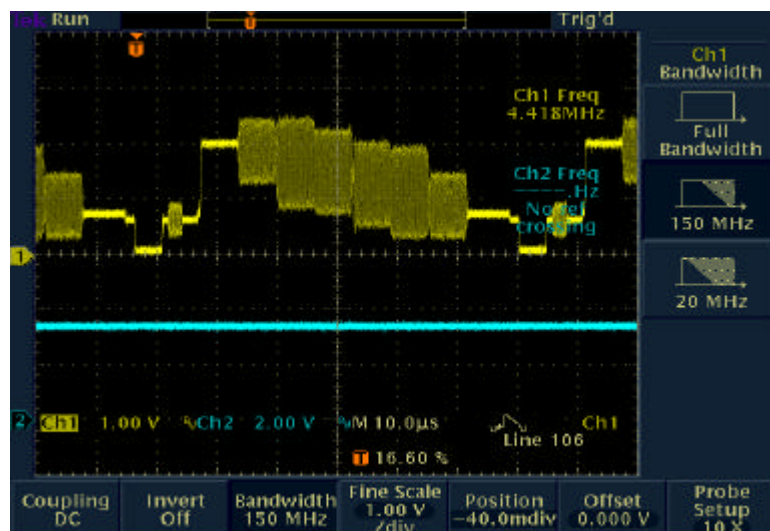

STRONG

RED -->

GREEN -->

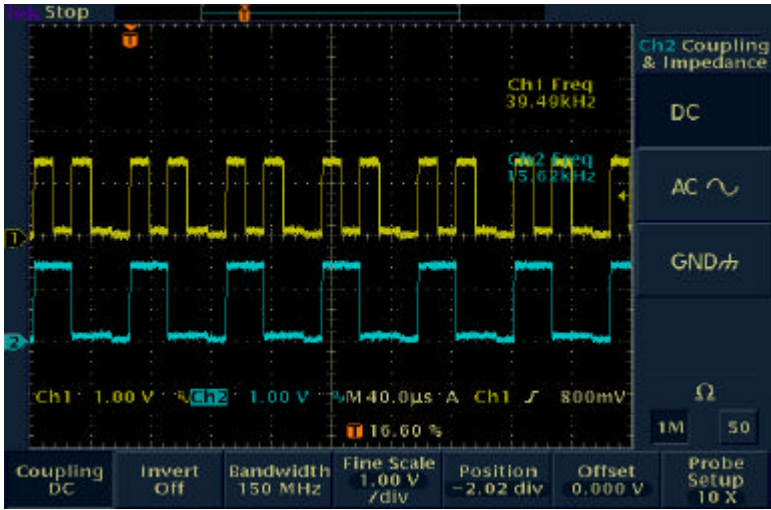

BLUE -->

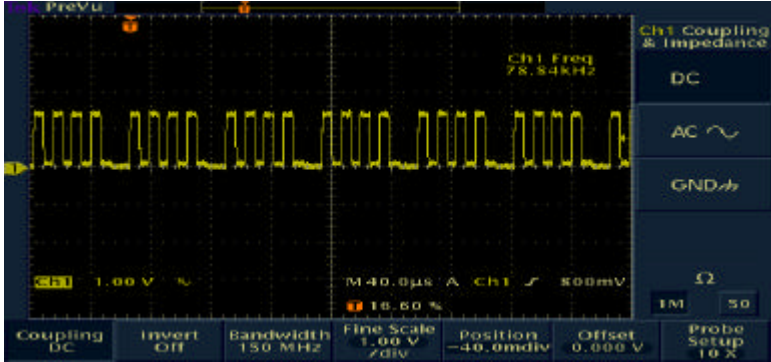



6. Materials list

6.1 Main PCB materials list

cc	Quantity	Reference	Part Number	VENDOR
1	1		PCB-MAIN ; IT612_R1.8 VER 1.8, 2Layer	
2	3	BD1,BD2,L15	CORE-FERRITE BEAD ; FCM2012C-101,100ohm	TAI-Tech
3	7	BD6,BD9,BD24,BD3,BD4,BD5,BD7	CORE-FERRITE BEAD ; SMB403025	TAI-Tech
4	4	L4,L5,L6,L7	INDUCTOR-SMD ; FCI1608-1R8K,1608 SIZE	TAI-Tech
5	7	L1,L2,L3,L10,L12,L13,L14	INDUCTOR-SMD ; 10uH, 10%, 2012	TAI-Tech
6	20	R8,R9,R16,R23,R35, R84,R90,R96,R98,R100, R103,R107,R116,R122,R148, R149,R162,R173,R176,R177	R-CHIP ; 1Kohm, 5%, 1/16W, DA, TP, 1608	HAN RYUK
7	28	R13,R17,R19,R20,R27,R32, R33,R34,R49,R50,R57,R60,R125, R128,R140,R144,R145,R146, R147,R150,R151,R152,R153, R156,R159,R167,R142,R143	R-CHIP ; 4.7Kohm, 5%, 1/16W, DA, TP, 1608	HAN RYUK
8	12	R36,R85,R89,R129, R130,R139,R141,R171,R172, R175,R178,R179	R-CHIP ; 10Kohm, 5%, 1/16W, DA, TP, 1608	HAN RYUK
9	2	R163,R164	R-CHIP ; 100ohm, 5%, 1/16W, DA, TP, 1608	HAN RYUK
10	3	R14,R15,R51	R-CHIP ; 3.3Kohm, 5%, 1/16W, DA, TP, 1608	HAN RYUK
11	1	R18	R-CHIP ; 10ohm, 5%, 1/16W, DA, TP, 1608	HAN RYUK
12	11	R21,R22,R24,R37,R38,R55, R123,R124,R126,R127,R166	R-CHIP ; 0ohm, 5%, 1/16W, DA, TP, 1608	HAN RYUK
13	1	R28	R-CHIP ; 150ohm, 5%, 1/16W, DA, TP, 1608	HAN RYUK
14	2	R30,R29	R-CHIP ; 18ohm, 5%, 1/16W, DA, TP, 1608	HAN RYUK
15	1	R31	R-CHIP ; 200ohm, 5%, 1/16W, DA, TP, 1608	HAN RYUK
16	15	R39,R97,R99,R104,R108,R115, R40,R41,R43,R44,R45,R46,R47,R42,R95	R_CHIP ;75ohm, 1%, 1/16W, DA, TP, 1608	HAN RYUK
17	4	R102,R168,R169,R192	R-CHIP ; 6.8Kohm, 5%, 1/16W, DA, TP, 1608	HAN RYUK
18	5	R3,R4,R161,R160,R121	R-CHIP ; 33ohm, 5%, 1/16W, DA, TP, 1608	HAN RYUK
19	1	R131	R-CHIP ; 15Kohm, 1%, 1/10W, DA, TP, 2012	HAN RYUK
20	1	R132	R-CHIP ; 33Kohm, 1%, 1/10W, DA, TP, 2012	HAN RYUK
21	1	R133	R-CHIP ; 5.1Kohm, 1%, 1/10W, DA, TP, 2012	HAN RYUK
22	1	R134	R-CHIP ; 20Kohm, 1%, 1/10W, DA, TP, 2012	HAN RYUK
23	1	R135	R-CHIP ; 300ohm, 5%, 1/10W, DA, TP, 2012	HAN RYUK
24	1	R137	R-CHIP ; 47ohm, 5%, 1/10W, DA, TP, 2012	HAN RYUK

STRONG

25	1	R136	R-CHIP ; 2.7Kohm, 5%, 1/8W, DA, TP, 3216	HAN RYUK
26	1	R138	R-CHIP ; 1.8Kohm, 5%, 1/8W, DA, TP, 3216	HAN RYUK
27	1	R12	R_CHIP ;16.9Kohm,1%,1/16W,DA,TP,1608	HAN RYUK
28	6	R93,R94,R109,R110,R111,R112	R-CHIP ; 560ohm, 5%, 1/16W, DA, TP, 1608	HAN RYUK
29	3	R58,R52,R53	R-CHIP ; 1.2Kohm, 5%, 1/16W, DA, TP, 1608	HAN RYUK
30	2	R101,R191	R-CHIP ; 20Kohm, 5%, 1/16W, DA, TP, 1608	HAN RYUK
31	2	R113,R184	R-CHIP ; 10Kohm, 5%, 1/10W, DA, TP, 2012	HAN RYUK
32	1	R185	R-CHIP ; 47Kohm, 5%, 1/10W, DA, TP, 2012	HAN RYUK
33	2	R1,R186	R-CHIP ; 4.7Kohm, 5%, 1/10W, DA, TP, 2012	HAN RYUK
34	1	R183	R-CHIP ; 100Kohm, 5%, 1/10W, DA, TP, 2012	HAN RYUK
35	1	R92	R-CHIP ; 100ohm, 5%, 1/10W, DA, TP, 2012	HAN RYUK
36	1	R182	R-CHIP ; 0ohm, 5%, 1/10W, DA, TP, 2012	HAN RYUK
37	2	R154,R157	R-CHIP ; 470ohm, 5%, 1/16W, DA, TP, 1608	HAN RYUK
38	1	R2	R-CHIP ; 620ohm, 5%, 1/16W, DA, TP, 1608	HAN RYUK
39	1	R5	R-CHIP ; 6.2Kohm, 1%, 1/16W, DA, TP, 1608	HAN RYUK
40	1	R6	R-CHIP ; 3.3Kohm, 5%, 1/10W, DA, TP, 2012	HAN RYUK
41	1	R91	R-CHIP ; 75ohm, 5%, 1/16W, DA, TP, 1608	HAN RYUK
42	5	R114,R117,R118,R119,R120	R-CHIP ; 75ohm, 1%, 1/10W, DA, TP, 2012	HAN RYUK
43	4	RA2,RA4,RA9,RA24,	R-NETWORK ; 10Kohm, 5%, 1/16W, L, CHIP, 4P, TP, 1608	HAN RYUK
44	1	RA1	R-NETWORK ; 1Kohm, 5%, 1/16W, L, CHIP, 4P, TP, 1608	HAN RYUK
45	9	RA3,RA8,RA13,RA14,RA19, RA20,RA23,RA15,RA16,	R-NETWORK ; 4.7Kohm, 5%, 1/16W, L, CHIP, 4P, TP, 1608	HAN RYUK
46	5	RA5,RA6,RA7,RA17,RA18,	R-NETWORK ; 100ohm, 5%, 1/16W, L, CHIP, 4P, TP, 1608	HAN RYUK
47	3	RA10,RA11,RA12	R-NETWORK ; 33ohm, 5%, 1/16W, L, CHIP, 4P, TP, 1608	HAN RYUK
48	86	C6,C9,C14,C17,C18,C19, C20,C27,C28,C29,C30,C44, C45,C46,C47,C48,C49,C60,C61, C62,C63,C64,C65,C66,C67, C68,C69,C70,C71,C72,C74, C75,C76,C77,C78,C79,C80, C81,C82,C83,C84,C85,C86, C87,C88,C89,C90,C91,C92, C93,C94,C95,C96,C97,C98, C99,C100,C101,C102,C103, C104,C105,C106,C107,C108, C109,C110,C111,C112,C113, C114,C115,C116,C117,C118, C119,C120,C121,C122,C123, C124,C125,C126,C135,C136,C137	C-CERAMIC, CHIP ; 100nF, +80-20%, 50V, Y5V, TP,1608	SAMWHA
49	5	C8,C32,C35,C38,C41	C-CERAMIC CHIP ; 22pF, 5%, 50V, NPO, TP, 1608	SAMWHA
50	1	C15	C-CERAMIC, CHIP ; 20pF, 5%, 50V, NPO, TP, 1608	SAMWHA
51	2	C24,C23	C-CERAMIC, CHIP ; 18pF, 5%, 50V, NPO, TP, 1608	SAMWHA

STRONG

52	4	C31,C34,C37,C40	C-CERAMIC, CHIP ; 270pF, 5%, 50V, NPO, TP, 1608	SAMWHA
53	4	C33,C36,C39,C42	C-CERAMIC, CHIP ; 330pF, 5%, 50V, NPO, TP, 1608	SAMWHA
54	8	C127,C128,C129,C130,C131, C132,C133,C134	C-CERAMIC, CHIP ; 470nF, +80-20%, 16V, Y5V, TP, 2012	SAMWHA
55	5	C10,C13,C16,C21,C22	C-CERAMIC, CHIP ; 1000pF, 5%, 50V, X7R, TP, 1608	SAMWHA
56	1	C7	C-CERAMIC, CHIP ; 1500pF, 10%, 50V, X7R, TP, 1608	SAMWHA
57	1	C1	C-CERAMIC, CHIP ; 1uF, +80-20%, 16V, Y5V, TP, 1608	SAMWHA
58	1	C2	C-CERAMIC, CHIP ; 51pF, 5%, 50V, COG, TP, 1608	SAMWHA
59	2	C11,C12	C-CERAMIC, CHIP ; 10nF, 10%, 50V, X7R, TP,1608	SAMWHA
60	2	D1, D2	DIODE - SWITCHING ; RLS4148,100V,450mA,LL-	Rohm
61	4	Q33,Q34,Q37,Q513	TR-SMALL SIGNAL ; KST3904-MTF,NPN, -60V, -	SAMSUNG
62	11	Q4,Q5,Q7,Q9,Q10,Q26,Q28, Q29,Q30,Q31,Q38	TR-DIGITAL ; DTC114EKA,NPN,100mA,200mW,SC-59	Rohm
63	1	U1	IC-MICROPROCESSOR ; L64108-54 MIPS/XPORT,240PIN,QFP	LSI logic
64	1	U2	IC-FLASH MEMORY ; SST39VF800A-90-4C-EK,1MX8BIT,TSOP,48P,3.3V	SST
65	1	U3	IC-DRAM ; KM416V1204CJ-6 or 7,1MX16BIT,SOJ,42P,3.3V	SAMSUNG
66	1	U8	IC-SDRAM ; KM416S1020CT-G7 or 8 or 10,512KX16BIT,TSOP,50P,3.3V	SAMSUNG
67	1	U4	IC-EEPROM ; AT24C64N-10SC-2.7,64KBYTE,SOIC,8P,3.3V	ATMEL
68	10	U21,U22,U25,U26,U27, U28,U29,U30,U31,U32	IC-CMOS LOGIC ; MM74HCT244MTC	Fairchild
69	1	U20	IC-CMOS LOGIC ; MM74HCT245MTC	Fairchild
70	1	U6	IC-CMOS LOGIC ; 74LCX04M,LOW VOLTAGE HEX INVERTER,SOP,14P	Fairchild
71	1	U23	IC-PLD ; EPM3032ALC44-10 (PLCC)	ALTERA
72	1	U11	IC-VIDEO ENCODER ; BT864AKRF,NTSC/PAL DIGITAL VIDEO ENCODER,PQFP,52P	Rockwell
73	1	U13	IC-D/A CONVERTER ; AK4323VF-E2,20BIT,VSOP,24P	AKM
74	1	U15	IC-AUDIO/VIDEO SWITCH ; CXA2126Q	Sony
75	1	U9	IC-TRANSMITTER/RECEIVER ; SP232ECN,SOIC,16P	SIPEX
76	1	U5	IC-RESET ; DS1811-10, SOT-23,3P	ILSSAN
77	1	U10 socket	SOCKET-IC ; 3262-44-T,PLCC	ILSSAN
78	1	U7	IC-A/V DECODER ; L64005F	LSI logic

Item	Quantity	Reference	Part Number	VENDOR
1	2	E8,E9	C-AL ; 47uF/50V-6.3*11*5, FORMING CUT TYPE	SAMWHA
2	1	E53	C-AL ; 220uF/16V-8*11.5*5, FORMING CUT TYPE	SAMWHA
3	3	E17,E12,E25	C-AL ; 4.7uF/50V-5*11*5, FORMING CUT TYPE	SAMWHA
4	3	E24,E41,E52	C-AL ; 10uF/50V-5*11*5, FORMING CUT TYPE	SAMWHA
5	3	E11,E57,E54	C-AL ; 100uF/16V-6.3*11*5, FORMING CUT TYPE	SAMWHA
6	4	E7,E16,E40,E51	C-AL ; 47uF/25V-5*11*5, FORMING CUT TYPE	SAMWHA
7	20	E1,E2,E3,E4 E5,E6,E13,E14,E15,E18,E21,E23,E39, E43,E44,E45,E47,E48,E49,E50	C-AL ; 10uF/25V-5*7*5, FORMING CUT TYPE	SAMWHA
8	2	E27,E35	C-AL ; 22uF/16V-5*7*5, FORMING CUT TYPE	SAMWHA

STRONG

9	6	E31,E29,E33,E34,E55,E56	C-AL ; 1uF/50V-5*11*5,FORMING CUT TYPE	SAMWHA
10	1	E10	C-AL ; 470uF/10V-8*11.5*5, FORMING CUT TYPE	SAMWHA
11	1	E59	C-AL ; 1000uF/10V-10*16*5, STRAIGHT CUT TYPE	SAMWHA
12	8	Q16,Q17,Q18,Q19,Q20,Q21,Q22,Q23	TR-SMALL SIGNAL ; 2N3904 TO-92 PKG,NPN,60V,40V,200mA,1.5W,TO-92	SAMSUNG
13	6	Q11,Q27,Q32,Q35,Q36,Q512	TR-POWER ; KTA1273Y,PNP,-30V,-30V,-2A,1W,TO-92L	KEC
14	1	F100	CIRCUIT-BREAKER ; RXE065,60Vrms,DIP,40A	MANSUNG
15	2	U14,U12	IC-VOLTAGE REGULATOR ; KA7805AT(TU),TO-220,3P	Fairchild
16	1	U19	IC-VOLTAGE REGULATOR ; KA317M(TU),TO-220,3P	Fairchild
17	2	Q8,Q3	FET-GaAs ; IRFZ34N(A), Advanced Power Mos FET	Fairchild
18	1	U39	OSCILLATOR-VCXO ; 13T-63AP,27MHz-3.3V	KONY
19	1	X2	CRYSTAL-UNIT ; 11.0592MHZ,0.0030%,HC-49/S,18pF,60ohm,BK	SHINYOUNG
20	1	S1	JACK-SCART ; 2203-42ST(-A-),DUAL,42P,RIGHT ANGLE TYPE	ILSSAN
21	1	J4	CONNECTOR-SOCKET ; 3302-09S-AFS-0.9P,RIGHT ANGLE SOKET TYPE	ILSSAN
22	1	J2	CONNECTOR-HEADER ; 5267-11,2WALL, 11P, 1R, 2.5mm, STRAIGHT	MOLEX
23	1	JP8	CONNECTOR-HEADER ; 2110-DS 10-G(100MIL),2.54mm PIN HEADER (straight dual row)	ILSSAN
24	1	P200,P201	CONNECTOR-PCMCI ; P1T2B1393,Long eject,2	OTAX
25	1	J5	JACK-RCA ; JS0401315N,4P,6MM	DAE RYUNG
26	1	J1	CONNECTOR-WAFER ; 14PIN,SW0500-14,FRONT	MOLEX
27	2	JP6,JP11	PLUG-CONNECTOR ; 2250-10P-DS-T	ILSSAN
28	1	U17	FREQ-MODULE ; TBMU 30311 IMP,950~2150MHZ	SAMSUNG
29	1	H1	HEAT SINK ; PRES B-TYPE,SIL,AL6063,30*15*22.5	INSUNG
30	3	Q1,Q2,Q6	TR-POWER ; KSB772-Y, PNP, 10W, TO-126, 160	Fairchild

Item	Quantity	Reference	Part Number	VENDOR
1	1	ASS'Y	SCREW ; TT2,BIN(+),WTH3X6	
2	1	ASS'Y	SMPS ; P-126A, NO POSITIONER	INSUNG
3	1	ASS'Y	CABLE-POWER ; KKJ640	YOUNGSHIM
4	1	U10	IC-MICROCONTROLLER ; AT89C51-12/16/20/24JC(I) (PLCC)	ATMEL

Item	Quantity	Reference	Part Number	VENDOR
1	1		SUB PCB ; IT612_R1.3 VER 1.3, 1Layer	
2	1	U16	RF-MODULATOR ; RMUP74055WT	SAMSUNG
3	2	JP7,JP10	CONNECTOR-SOCKET ; 2250-10S-DS-T	ILSSAN



6.2 Front PCB materials list

Item	Quantity	Reference	Part Number	Vendor
1	2	BC1,BC2	CR051BX7R104Z500R	SAMWHA
2	7	D1,D2,D3,D4,D5,D6,D8	1N4001	PHILIPS
3	1	J1	14P 162020	MOLEX
4	1	FOUR DIGIT DISPLAY	LFD4162-10/SP8	LIGITEK
5	1	FOUR DIGIT DISPLAY support	support : 10mm	
6	1	LED2	LH3330	LIGITEK
7	1	LED4	LG3330	LIGITEK
8	2	LED support	support : 7mm	
9	4	Q1,Q2,Q3,Q4	2N2222A	SAMSUNG
10	7	R5,R6,R7,R8,R 14,R15,R18	RNL 1/6 102 JT -52	HAN RYUK
11	1	R27	RNL 1/6 330 JT -52	HAN RYUK
12	8	R19,R20,R21,R22,R23,R24, R25,R26	RNL 1/6 151 JT -52	HAN RYUK
13	1	EC1	RSS/TS 25-47 5*11 2.5	DAEWOO
14	7	S1,S2,S3,S4,S5,S6,S7	KPT-1115A	KYUNG IN
15	2	U1,U2	74HCT374N	TI,ST,LG
16	1	U3	TSOP1238	
17	1	U3 support	support : 10mm	
18	1	front PCB	ITF612F-R1.2	

7. Software download instructions(OTA and PC download)

7.1 Program Download

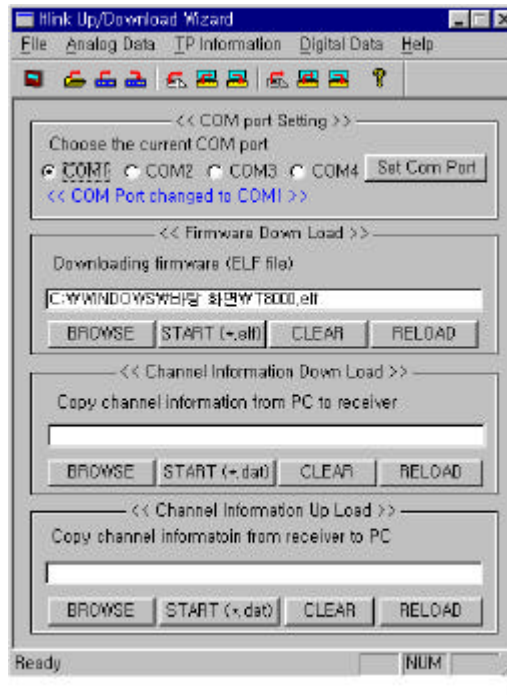

Firmware download

You can download firmware to receiver

- Press "BROWSE" button to select firmware (ELF) to downloading.
- After selecting firmware, you can start downloading by pressing "START" button.
- You can see progressing bar while downloading
- The receiver will automatically restart when downloading is finished.

Channel Information upload

You can save channel information of receiver to PC file by using this function

- You have to select a file to save in PC by pressing "BROWSE" button.
- Press "START" button to start uploading

Channel Information download

You can download channel information saved above to receiver

- You have to select a file to download to receiver by pressing "BROWSE" button.
- Press "START" button to start downloading

7.2 System Upgrade

If there is a new version of software available for your receiver, you are able to download it

automatically via the satellite signal of ASTRA 19.2 East.

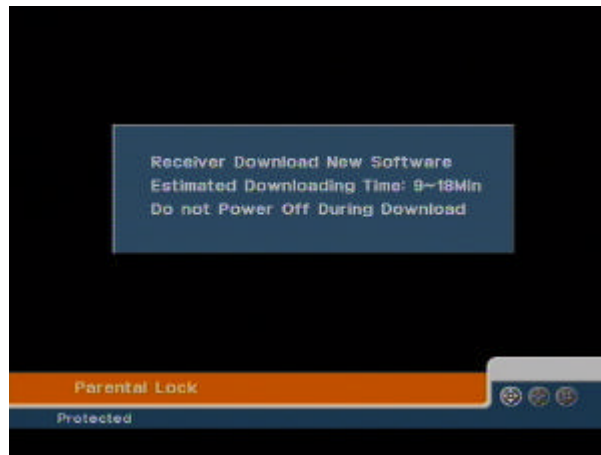

1. Please wait while your receiver is checking if your software version is the newest one available.
2. If you already have the newest version nothing will happen, and you can leave the menu. When you need the newest version software, the receiver will automatically download that version from the satellite signal. After the download is finished, your screen will turn green for a few seconds while the receiver is re-booting.

When the screen is back is to normal, you can leave the menu.

Tips : Do not turn off your receiver while you are downloading new software.

Be sure that your receiver is connected to the satellite signal of ASTRA 19.2 East.

7.3 SRT4355 U23(EPM3032ALC44-10) programming method

1. MAX+plus II icon double click

STRONG

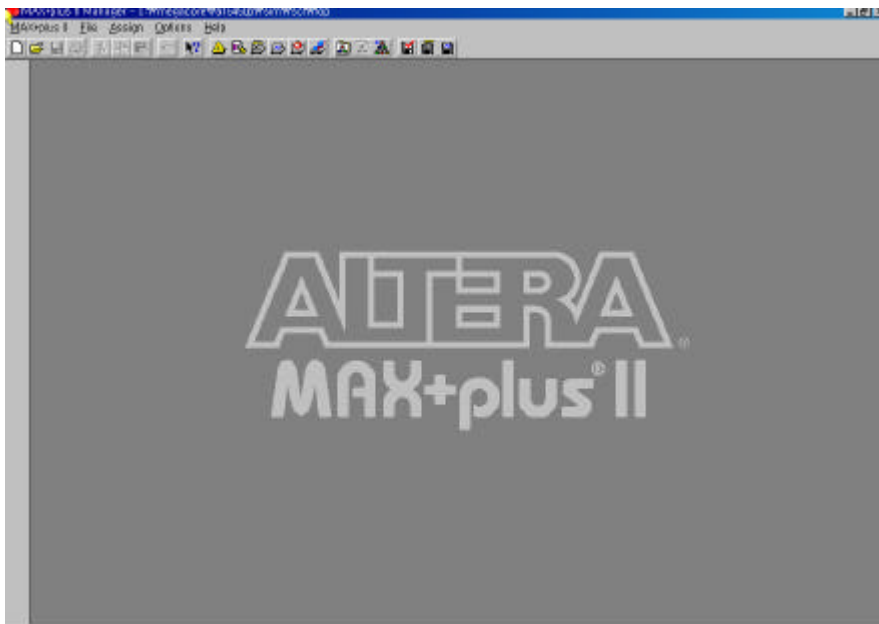

2. MAX+plus II menu clock -> "Programmer" clock on sub menu

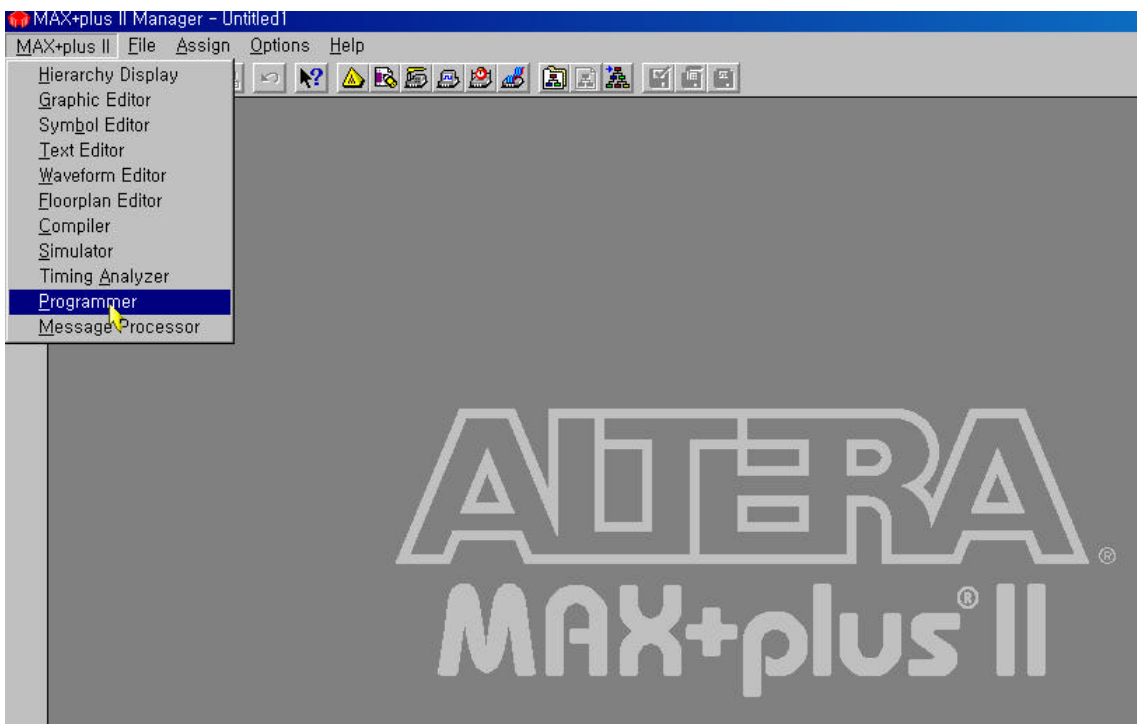

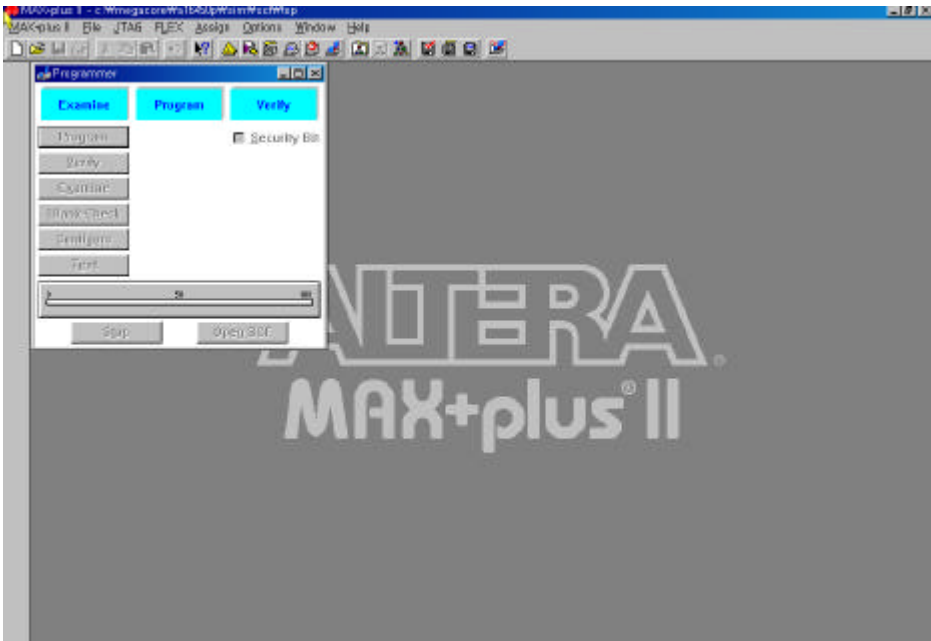

3. "Option" -> "Hardware setup" -> ByteBlaster(MV)

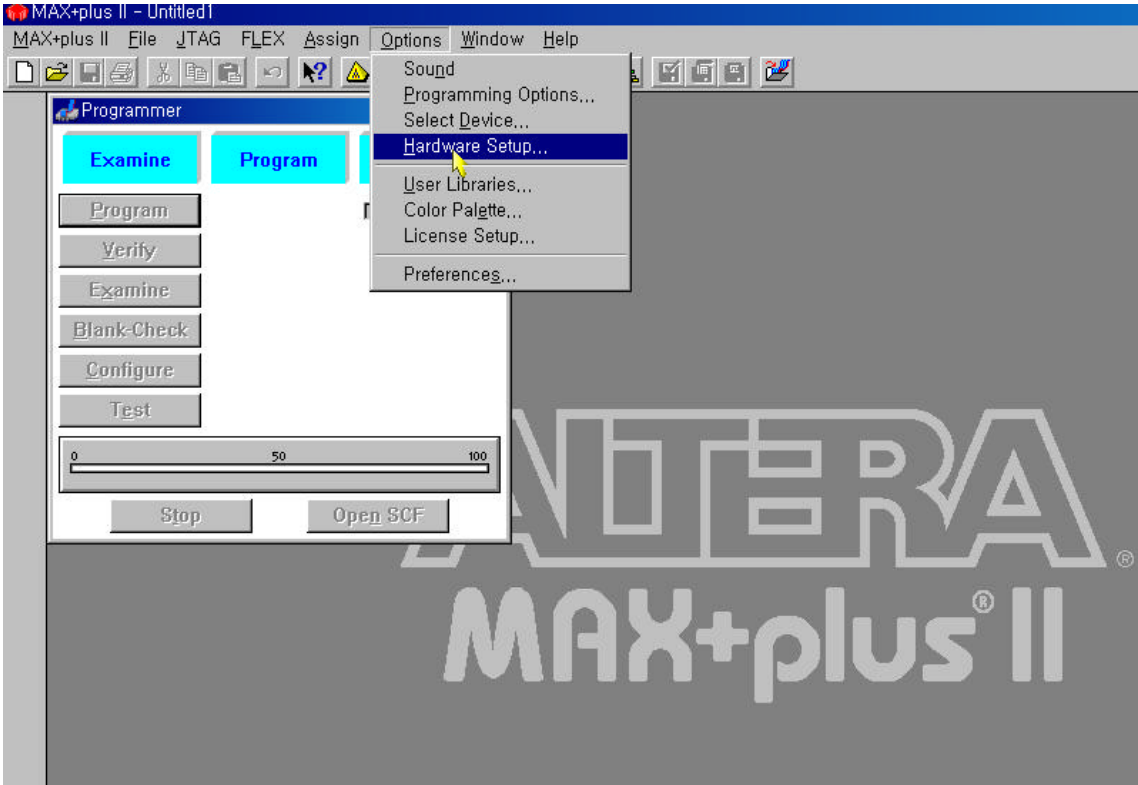

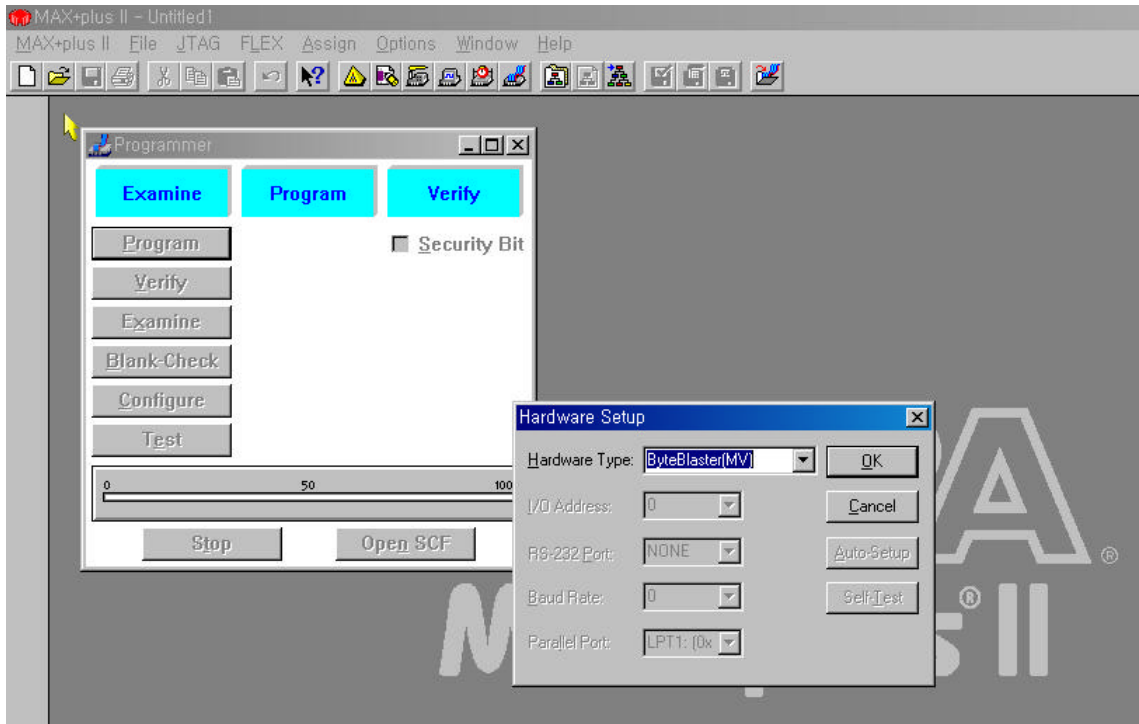

“File” on main menu → “Select Programming File” -> select programming file(srt4355.pof) in directory

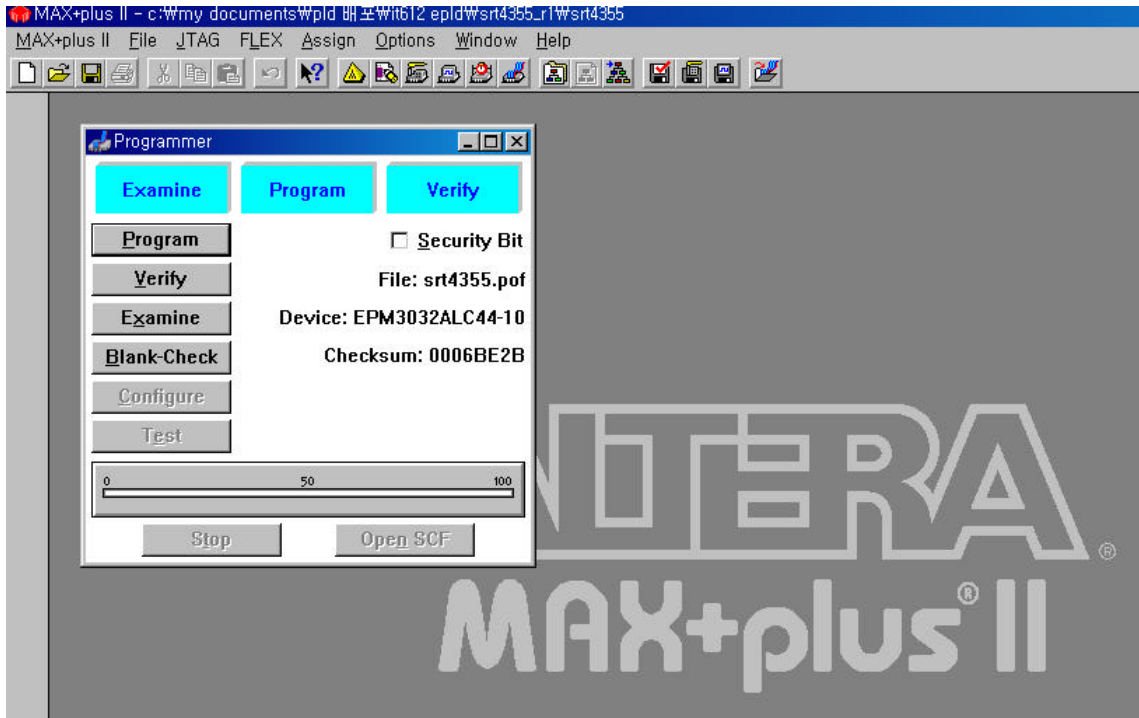

4. select “Program” -> down loading start

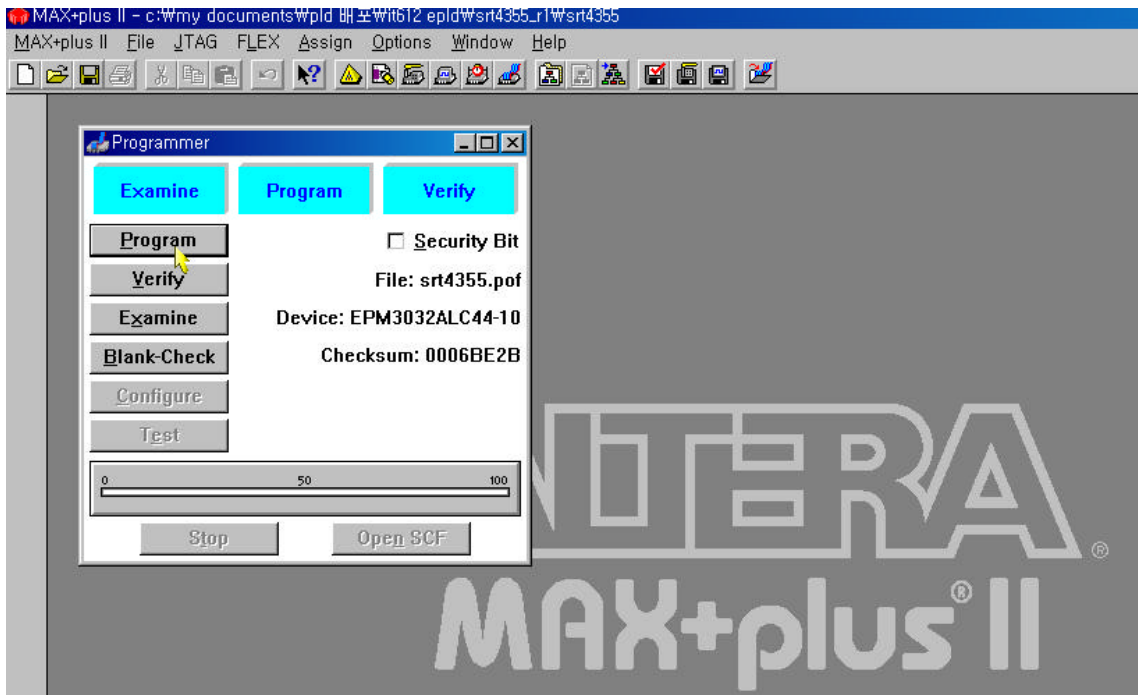

5. STB power off or cable not connected, if it have error message

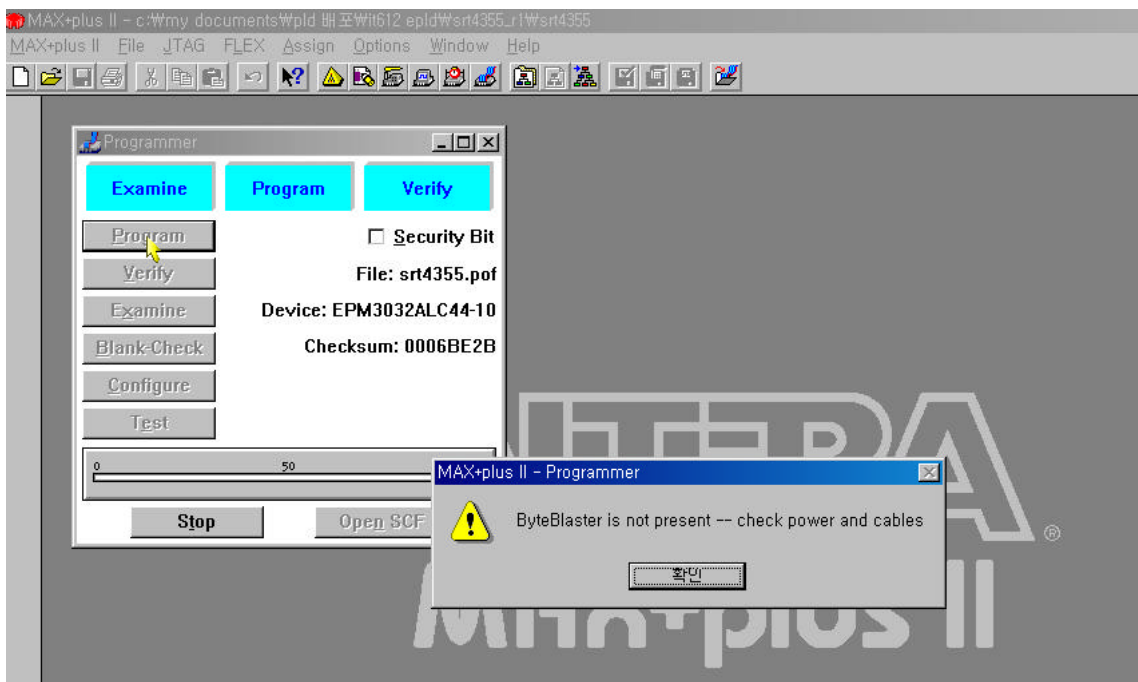

6. if you want to check device check sum, select "Examine"

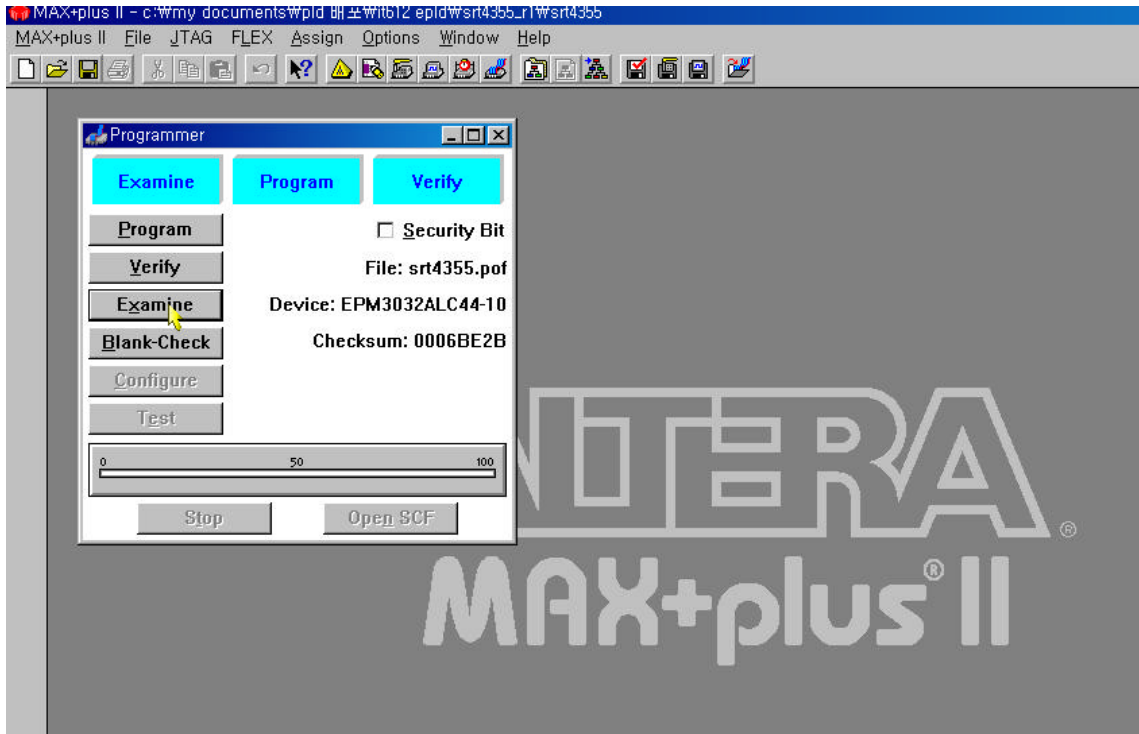

8. Specification of required cables for software download

8.1 PC Download Cable

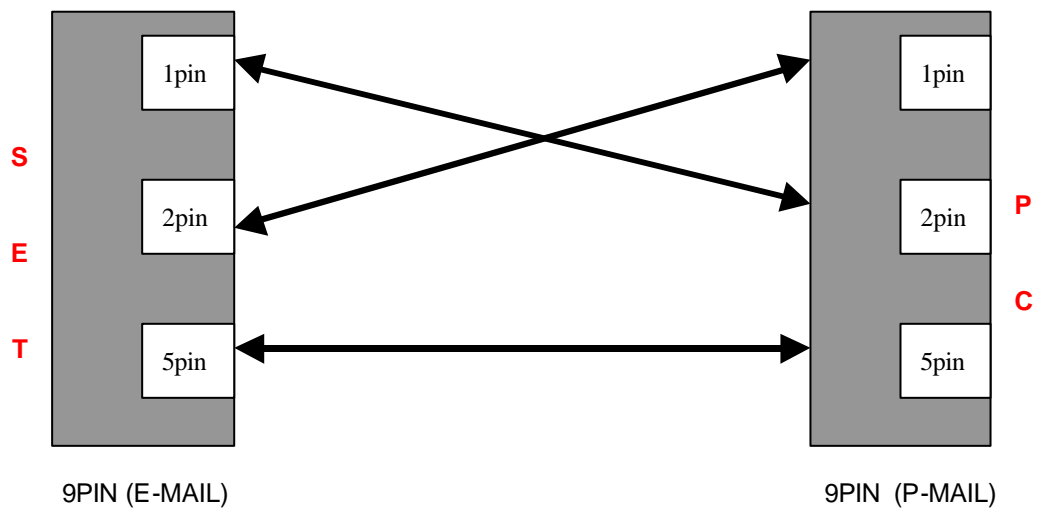

8.2 U23 Download Cable

ByteBlaster Parallel Port Download Cable

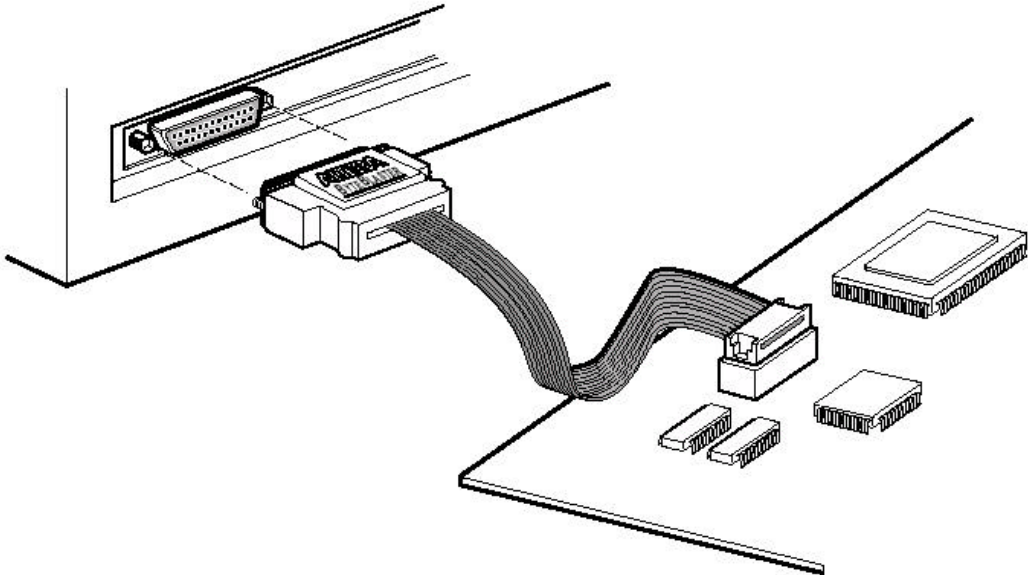

Dimensions are shown in inches. The spacing between pin centers is 0.1 inch.

